



Prototype Use Case Scenarios

D3.1

BEST

Grant:

699298

Call:

H2020-SESAR-2015-1

Topic:

Sesar-03-2015

Information Management in ATM

Consortium coordinator:

SINTEF

Dissemination Level:

PU

Edition date:

20 March 2018

Edition:

01.05.00 Final Version

Founding Members



Authoring & Approval

Authors of the document

Name/Beneficiary	Position/Title	Date
Eduard Gringinger/FREQUENTIS	Project/Member	28 February 2018
Bernd Neumayr/JKU	Project/Member	28 February 2018
Christoph Fabianek/FREQUENTIS	Project/Member	28 February 2018
Alexandru Savulov/FREQUENTIS	Project Member	15 May 2017

Reviewers internal to the project

Name/Beneficiary	Position/Title	Date
Scott Wilson	Project/Member	07 March 2018
Christoph Schütz	Project/Member	01 March 2018
Bernd Neumayr	Project/Member	01 March 2018
Audun Vennesland	Project/Member	10 May 2017

Approved for submission to the SJU By — Representatives of beneficiaries involved in the project

Name/Beneficiary	Position/Title	Date
Approved by consortium in accordance with procedures defined in Project Handbook.	All partners	20 March 2018

Document History

Edition	Date	Status	Author	Justification
00.00.01	03/11/2016	PCOS	Savulov	PCOS review
00.00.02	04/04/2017	Intermediate draft	Savulov/Gringinger	Intermediate review
00.01.01	21/04/2017	Intermediate approved	Savulov/Gringinger	Operational comments
01.00.00	08/05/2017	Final draft	Savulov	Start Final version
01.01.00	11/05/2017	Final draft	Wilson/Vennesland/Gringinger	Feedback from Wilson and Vennesland
01.02.00	16/05/2017	Final draft	Savulov/Gringinger	Feedback from JKU
01.03.00	26/05/2017	Final approved	Wilson/Gringinger	Final review from Wilson
01.04.00	07/12/2018	Final draft	Gringinger/Neumayr	Feedback from SJU
01.05.00	09/03/2018	Final approved	E. Gringinger	Answered additional questions raised during the SJU review meeting



Achieving the **BE**nefits of **SWIM** by making smart use of **Semantic Technologies**

This deliverable is part of a project that has received funding from the SESAR Joint Undertaking under grant agreement No 699298 under the European Union's Horizon 2020 research and innovation programme.

Abstract/Executive Summary

Project BEST is concerned with devising, drafting, designing, developing and deploying the “semantic container” approach for demonstration purposes. The adoption of the “semantic container” approach opens the door for the development of novel operational methods as a result of it offering real possibilities for increased decisional process speed.

First, the document lists and describes the background necessary to understand (also for non SESAR members) the area of interest. It gives an overview about relation of SWIM and BEST and how the semantic container extends the SWIM concept. The document gives an overview and explanation of the BEST semantic container approach, its various core technical aspects and how it is supposed to be used in the context of a SWIM enabled environment. A parallel between the SWIM-only and SWIM-and-BEST enabled operational environment is drawn in order to highlight the benefits that the BEST semantic container approach will have to offer in the eventuality of its introduction.

The document details use cases, in chapter 3 and chapter 4 supporting the development, configuration and deployment of experimental prototype applications to demonstrate the possibilities semantic technology can offer. It demonstrates the semantic container approach's feasibility, viability and usefulness as an addition to the already well-studied SWIM concept, to support and enhance the processing of aeronautical and meteorological data, improve its availability and quality and reduce data retrieval and processing cost.

Then, the document lists and describes two use cases scenarios derived from use cases to be supported and implemented by the prototype applications in order to achieve the previously stated goal.

To help the reader better understand the addressed topics, the document provides explanations on the current operational methods and process as well as description of technical terms and concepts used to define and describe the above-mentioned scenarios and use cases. A brief explanation of currently devised SWIM compliant services is provided as an annex.

Table of Contents

Abstract/Executive Summary	3
1 Introduction: About this document	6
1.1 Purpose.....	6
1.2 Intended Readership	6
1.3 Relationship to other deliverables.....	7
2 Background	9
2.1 Motivation	9
2.2 Current Operational Information Exchange	11
2.3 SWIM enabled Operational Method.....	13
2.4 BEST enabled Operational Method.....	15
2.4.1 Semantic Container Derivation Chains	16
3 Prototype Use Cases	19
3.1 Use Case: Aeronautical Information	21
3.1.1 SWIM Use Case: Retrieve Aeronautical Information Feature.....	21
3.1.2 BEST Use Case: Retrieve Aeronautical Information Feature.....	22
3.2 Use Case: MET Information	24
3.2.1 SWIM Use Case: Subscribe/Publish MET Information	24
3.2.2 BEST Use Case: Subscribe/Publish MET Information	25
3.3 Use Case: Digital NOTAM	30
3.3.1 SWIM Use Case: Request/Subscribe/Publish Digital NOTAM.....	30
3.3.2 BEST Use Case: Request/Subscribe/Publish Digital NOTAM.....	30
3.4 Use Case: Flight Plan	33
3.4.1 SWIM Use Case: Request/Subscribe/Publish Flight Plan	33
3.4.2 BEST Use Case: Request/Subscribe/Publish Flight Plan	34
3.5 Use Case: Pre-Flight Briefing	36
3.5.1 SWIM Use Case: Subscribe/Publish Pre-Flight Briefing.....	37
3.5.2 BEST Use Case: Subscribe/Publish Pre-Flight Briefing	37
3.6 Benefits	40
3.6.1 Defined Quality of Information.....	40
3.6.2 High Availability of Information	40
3.6.3 Decreased Network Load	41
4 Prototype Use Case Scenarios	42
4.1 Use Case Scenario: Flight YSSY – OMDb.....	42
4.2 Use Case Scenario: Flight OMDb – LOWW	46
5 Conclusion and Future Work	50

5.1	Conclusion.....	50
5.2	Future Use Cases	50
6	<i>References</i>	54
7	<i>Table of Figures</i>	56
8	<i>Abbreviations</i>	57
9	<i>APPENDIX A: Anatomy of a Flight</i>	60
10	<i>APPENDIX B: Operational Scenario</i>	62
10.1	Rerouting of Flights	62
11	<i>APPENDIX C: SWIM Services</i>	64
11.1	Provider Service: Aeronautical Information Feature	64
11.2	Provider Service: Aeronautical Information Notification	64
11.3	Provider Service: Flight Plan Distribution.....	65
11.4	Provider Services: Meteorology	65
11.5	Provider Service: Integrated Digital Briefing	66

1 Introduction: About this document¹

This document describes the use cases and use case scenarios for the prototype demonstrating the semantic container approach of BEST. The use case scenarios are based on the assumption that SWIM is implemented and ready to use within the European ATM network.

Chapter 2 describes the motivation for this work. This includes a comparison between the current operational information exchange, a SWIM enabled operational method and SWIM with semantic containers. Therefore in section 2.4 the relation of a semantic container and SWIM is described.

The main goal of this document is to define generic use cases showing the benefits of the BEST semantic container as defined in deliverable D2.1 (Schuetz, Neumayer, & Schrefl, D2.1 Techniques for ontology-based data description and discovery in a decentralized SWIM knowledge base, 2018). The use case scenarios describe are than used in one fixed operational scenario, for the experimental prototype described in deliverable D3.2. In addition, this document lists further use cases for the future which have not been the main target of this project but are worth to mention to give an indication about the potential of semantic containers within SWIM.

1.1 Purpose

The primary focus of work package 3 is to develop an experimental prototype to show the benefits of the BEST semantic container based on the use case scenarios, derived from use cases, described in this document. In order to do this, this deliverable illustrates the capabilities of BEST semantic containers in given SWIM enabled operational scenario. The prototype enables experimentation and evaluation of using semantic technologies in a SWIM enabled environment. The Grant Agreement describes the content of this deliverable as follows:

3.1 Task Description: “This task will develop a set of representative use case scenarios that will guide the prototype development and execution in Task 3.2. The use cases identified will in an early phase be discussed and validated with industrial stakeholders in WP 4 to ensure industrial relevance.”

3.1 Deliverable Description: “This deliverable is provided as a report that includes a set of use case scenarios that will guide the development of the Prototype SWIM-enabled Applications.”

1.2 Intended Readership

The intended readerships of this document are operational people that will benefit from SWIM, SWIM developers, relevant SWIM industry and future SWIM (information) providers and consumers (e.g.: ANSPs, airlines, airports, weather organizations, etc.).

¹ The opinions expressed herein reflect the author’s view only. Under no circumstances shall the SESAR Joint Undertaking be responsible for any use that may be made of the information contained herein.

1.3 Relationship to other deliverables

The use cases demonstrate the wide scale impact of the BEST semantic containers. The use case scenarios are fundamental as they are used as baseline for the experimental prototypes. From the set of use cases, they will be developed and described in D3.2 (Gringinger & Fabianek, 2018) using semantic components specified and developed in WP 1 (Ontology Development and Compliance Validation) and WP 2 (Semantic Container Management). For example, the exchanged information identified in the use cases enable to identify which exchange information model was used within D1.1 (Vennesland, Neumayr, Schuetz, & Savulov, 2017) and which granularity of the ontology modules is necessary to support the use cases besides technological aspects. The use cases provided input for the composition of semantic containers described in D2.1 (Schuetz, Neumayer, & Schrefl, 2018) and influenced both deliverables in an iterative way. D3.1 will be used as input for future deliverables targeting experimental prototype application D3.2 (Gringinger & Fabianek, 2018), D2.2 (Schuetz, Neumayr, & Schrefl, 2018) the theoretical approach of the semantic container and guidelines for ontology modularization and software developer D5.1 (Brataas, Neumayr, Schuetz, & Vennesland, 2018) and D4.4 (Vennesland, Gringinger, & Mirhossein, 2018).

Deliverable	Relationship
D 1.1 Experimental ontology modules formalizing concept definition of ATM data	The ontology modules developed in D 1.1 can serve as the fundamental for the faceted ontology-based description of semantic containers. The ontology modules developed in D 1.1 are used for the baseline for the use case scenarios.
D 2.1 Techniques for ontology-based data description and discovery in a decentralized SWIM knowledge base	The definitions applied in D 2.1 in order to initialize the semantic container approach are essential for this deliverable to show the possibilities of semantic containers and their benefits.
D 2.2 Ontology-based techniques for data distribution and consistency management in a SWIM environment	In D 2.2 the semantic container approach will be extend with mechanisms for handling distribution of containers across different nodes, adding provenance information to the administrative metadata, distinguishing between logical and physical containers for distributed allocation.
D 3.2 Prototype SWIM-enabled applications	The experimental prototypes in D 3.2 will demonstrate practicality of the semantic container approach in a SWIM setting.
D 4.4 Tutorial for Software Developers	The tutorial will describe how software developers can write SWIM applications using semantic containers for data management and discovery.
D 5.1 Scalability Guidelines for Semantic SWIM-based Applications	While we conduct experiments concerning principal feasibility, D 5.1 will formally investigate scalability aspects of the semantic container approach.

D 5.2 Ontology Modularisation Guidelines for SWIM The guidelines will describe how to develop ontology modules for the semantic container approach.

2 Background

In this chapter, the key concepts of the semantic container approach in relation to the current operational methods are discussed. Section 2.1 motivates the initial need which led to the semantic container approach. Section 2.2 mentions the current operational information exchange in order to understand the useful step towards SWIM. Section 2.3 outlines the future operational method with SWIM rolled out. The purpose of the new technology stack defined and the possibilities for future information exchange in a SWIM-enabled environment. Section 2.4 introduces the basic idea of semantic-container-based management in a SWIM-enabled environment and gives an overview what value-added data can add to SWIM.

2.1 Motivation

The motivation for the semantic container approach was born during the work on several SESAR 1 projects. The majority of operational scenarios used in ATM related (research) projects are associated with a flight or a Flight Plan (FPL). This lead to the generic assumption that, a route can be seen as baseline for ATM related data aggregation Figure 1 shows all Air Traffic Services (ATS) routes in Germany.

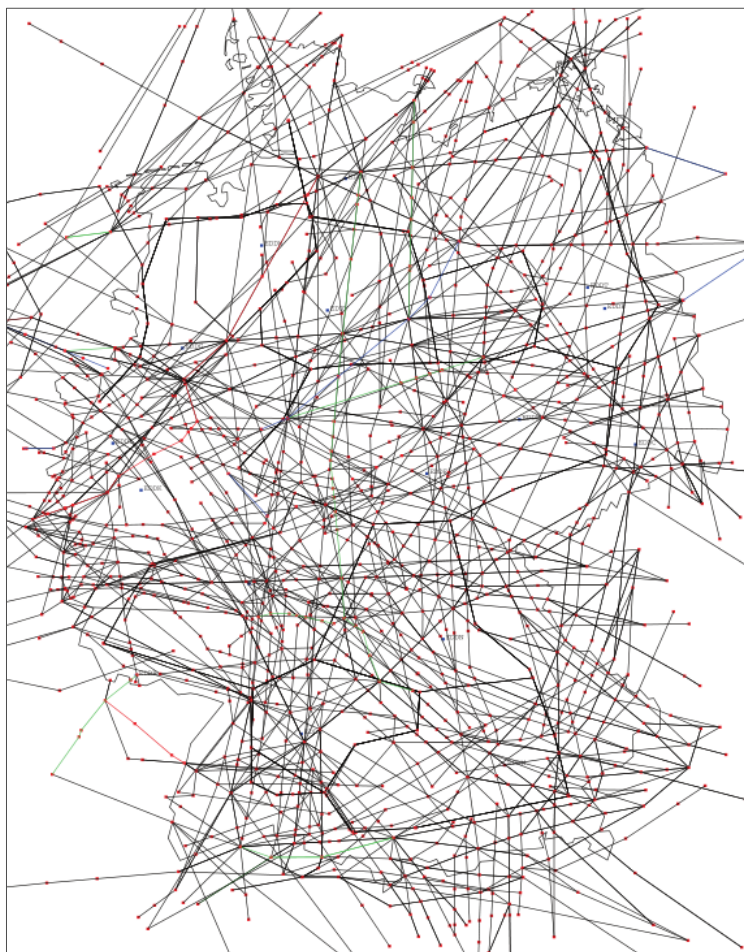

Figure 1: Air Traffic Services routes for Germany (DFS Deutsche Flugsicherung, 2012)

Taking this into account, the first question was how this knowledge could be used to even further improve the SWIM concept to make sure that the right information is received at right place and time. In a first step it was analysed at which stage information could be pre-aggregated, pre-filtered and pre-prioritized so that SWIM applications can use information even more prepared than SWIM services support this task right now.

All operations in the ATM domain and beyond (taxi organizations, catering, fire brigade, etc.) are as a matter of fact directly or indirectly related to a flight. This observation leads to the development of the semantic container approach. A semantic container focusses around the flight (route) including aggregation, composition and filtering of additional information besides the baseline data for a route. ATM information exchange models like Aeronautical Information Exchange Model (AIXM 5.1) (Eurocontrol, Aeronautical Information Exchange Model (AIXM), 2016), ICAO Meteorological Information Exchange Model (IWXXM) 2.1 (Eurocontrol, Weather Information Exchange Model (WXXM), kein Datum) and Flight Information Exchange Model (FIXM) 4.0 (Eurocontrol, Flight Information Exchange Model (FIXM), 2016) define SWIM compliant information exchange formats.

Semantic containers can be combined for specific customer needs. For example it would make sense to create a semantic container for Airports, ANSPs, Airlines, etc. which than could be reused by SWIM applications instead of querying and aggregating the information in a redundant way. A BEST semantic container associated with a feature can contain weather messages/events, contamination information while being associable with one or more flights. Useful semantic containers could be combined for a specific route, airport, area or airspace.

Figure 1 shows all Air Traffic Services (ATS) routes for Germany, these are the main routes used for civil aviation. With the BEST approach in place for each of the main routes a container can be combined collecting weather, aeronautical and other relevant data. Figure 2 shows the flight routes of inner Germany flights. Semantic containers can collect the relevant data sets at least for the heavily used routes in order to improve the SWIM network performance, reliability and could even improve the quality by adding additional information (see section 2.4 and section 3.6). The BEST container will collect the needed information for all main inner routes and provide all SWIM applications, which will process flight plans with the pre-calculated data sets. This will save all SWIM-enabled applications this prior filtering step. Since the collection of data in a container is operational independent the BEST container can be used in a generic way.

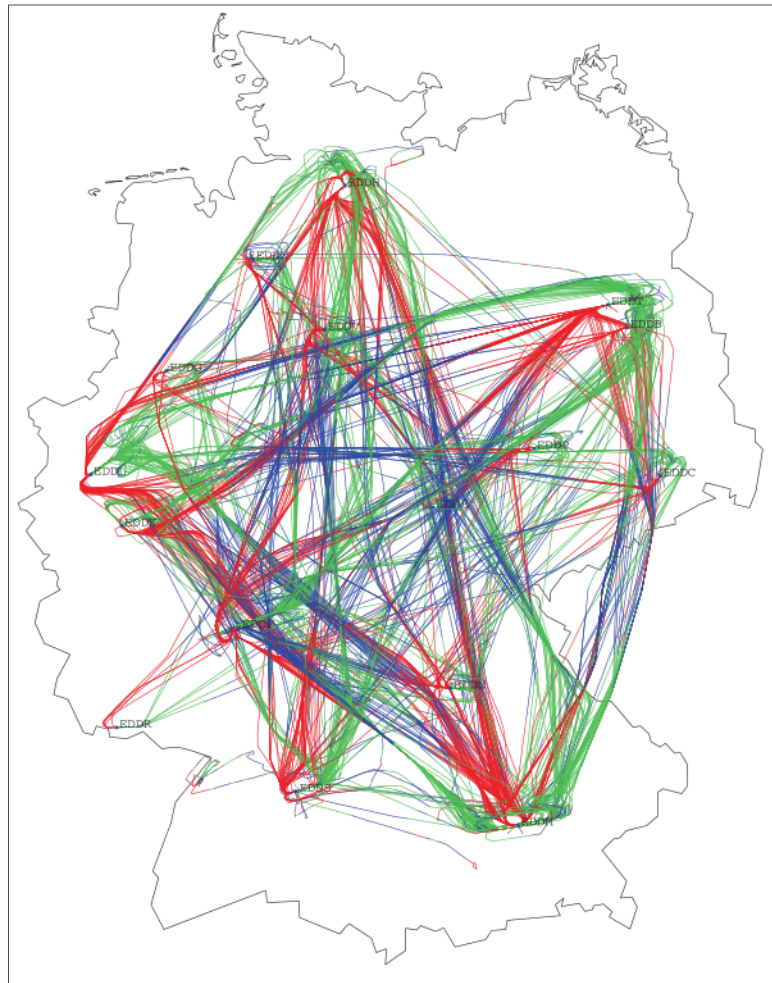

Figure 2: Flight routes of inner Germany flights (DFS Deutsche Flugsicherung, 2012)

2.2 Current Operational Information Exchange

Currently, decision making relies on the experience of air traffic controllers and is not done using a formal optimization model. Flight Operations (AOC, CPT, FO) creates flight plans, prepares weather information for the flights, and considers the NOTAMs for the flight path. For long-haul flights, the "pilot briefing" (flight-crew preparation) takes place there. The flight documents are transported by a document driver to the aircraft parking position and stored there in a document compartment. The Ramp Agent is then responsible for handing over the documents to the flight crew. For the operational process the whole ATC network available is used. Figure 3 gives an overview about generic functions of ATC systems. The current operational procedures are voice centric and most of the ATC information exchange is established via voice systems.

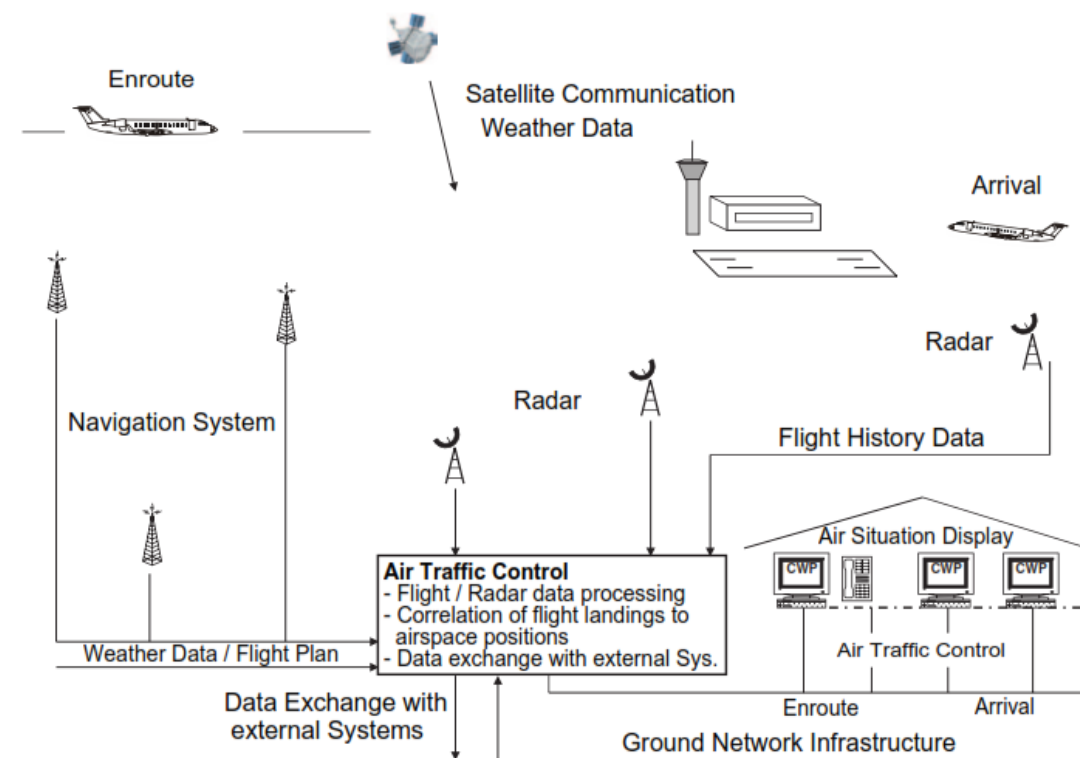

Figure 3: Overview of functions of generic Air Traffic Control systems

Rerouting provides a good example of current operational information exchanges. A reroute is an alternative offer to an airspace user in case of substantial delay, unavailability of a filed route or flight efficiency purposes. “What-if” reroute and group rerouting are functions within the Network Manager (NM) run by Eurocontrol that are designed to assist the Network Manager Operations Centre (NMOC) staff to find viable alternative routes. The Enhanced Tactical Flow Management System (ETFMS) considers the routes as well as the possible flight level limitations and gives the consequent result in terms of delay, miles to fly, fuel, and route charge information. In case of significant disruption to the Network, and in order to reduce delays in a particular area or assist a flight suffering a disproportionate delay, according to the Eurocontrol Network Manager (Eurocontrol, ATFCM Operations Manual - Network Operations Handbook, 2017) the NM tactical team shall:

“Identify any flight(s) that are significantly delayed.

Set in the ETFMS the necessary parameters for the calculation of the reroute.

Decide on how many flights should be rerouted.

Coordinate with the responsible NM tactical team member to ensure that the situation is not likely to change / improve in the next couple of hours.

Assess the Network Impact Display (NID) in order to identify the best Controlled Time of Arrival (CTO) / Calculated Take-Off Time (CTOT)

Coordinate with the Flow Management Positions (FMP) that could be heavily impacted.

Select the correct option according to the purpose of the rerouting e. g. Air Traffic Flow and Capacity Management (ATFCM), Flight Efficiency Initiative (FEI), Aircraft Operator What-If-Reroute (AOWIR). Send Rerouting Proposal messages (RRP).”

During the tactical phase, the NM monitors the delay situation and where possible, identifies flights subject to delays that would benefit from a reroute. When the Network situation permits, re-routing proposals can be sent to propose more efficient routes to airspace users. This is achieved by selecting a flight and then either (Eurocontrol, ATFCM Operations Manual - Network Operations Handbook, 2017):

*“Choosing an alternative route or
Asking ETFMS to process all possible options.”*

In both cases ETFMS considers the routes as well as the possible flight level limitations and give the consequent result in terms of delay, miles to fly and Central Route Charges Office (CRCO) route charge information. The NM may, depending on the circumstances, consult the Aircraft Operator (AO) concerned about their final selection. Once the final decision is taken, the NM will then propose the selected route which will result in the booking of a slot for that flight and at the same time trigger the sending of a Rerouting Proposal (RRP) message to the originator, associated with the appropriate comment. AOs who wish to benefit from the offer shall consequently modify their flight plan (either with a Change (modification) message (CHG) or a Flight plan cancellation message (CNL) and refile using the Replacement Flight Plan Procedure (RFP). To secure the new CTOT, the CHG / new Filed Flight Plan (FPL) should be received before the Respond by (RESPBY) time in the RRP. Upon the reception of the new route in the flight plan, the ETFMS shall merge the new route with the proposal. Then SLC, SAM or SRM messages shall be transmitted by the NM as appropriate.

The communication architecture shown in Figure 3, currently is voice centric. The operational process today takes some time for the communication between all the different stakeholders involved. In the worst case it can lead to the situation that the flight cannot be rerouted but has to travel through the storm front. The following sections show the difference with SWIM and SWIM with semantic containers in place.

2.3 SWIM enabled Operational Method

The European SWIM was and is advertised as new paradigm for sharing ATM information. The chosen technology stack has already proven its advantages in other domains. Instead of focusing on new operational processes SWIM is a technical enabler. Besides commonly agreed and understood data standards and information models, the new technologies used within the SWIM concept are also the enabler to do more advanced things than the operational processes can cover today.

The technical changes that are necessary to implement SWIM will enable the possibility to more efficient information exchange. To fully unleash the power of SWIM it also will be necessary to rethink today's operational procedures. This might also lead to complete new structure of existing Air Navigation Service Provider (ANSPs). With the SWIM information exchanges in place new knowledge can be gained by combining, aggregating and semantically enhancing it.

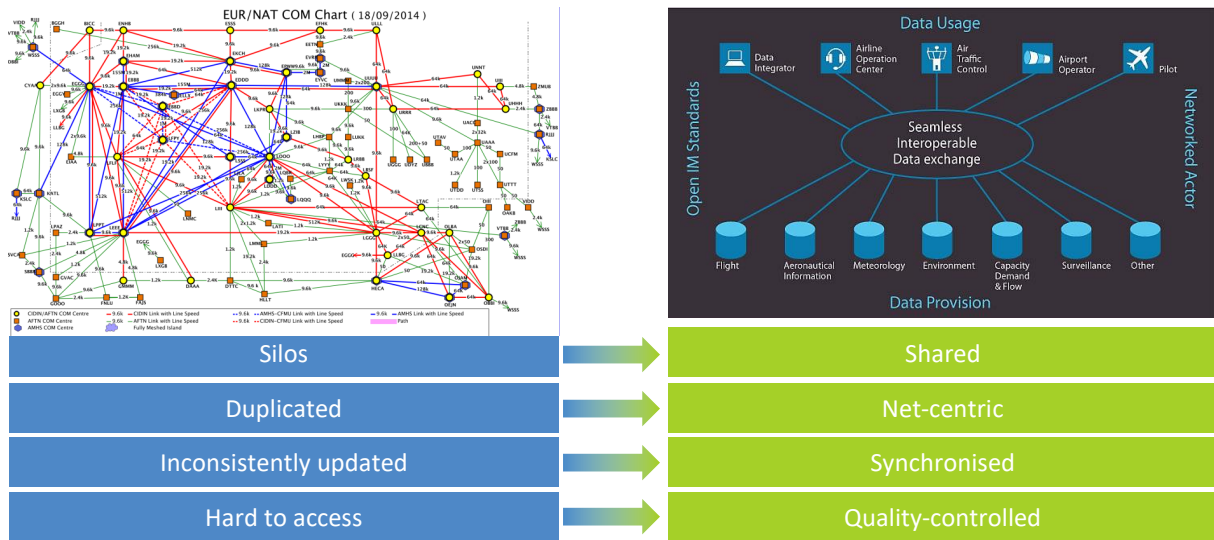

Figure 4: ATM Transition to SWIM

The SWIM-enabled operational method involves various data providers which exchange information via standardized services defined by the Information Service Reference Model (ISRM). In addition the ATM Information Reference Model (AIRM) defines the payload based on existing information exchange models in a harmonized way. Information can then either be subscribed or requested by a consumer from the SWIM data pool. This is a major step to change the operational process from voice centric to a service centric solution.

Coming back to the example, the rerouting of flights involves different systems, an AIM server, various Approach and En-Route Air traffic control (ATC) centres, and a SWIM user interface displaying the ash cloud and the trajectories received (similar scenarios have been used multiple times in various SWIM Demos performed in SESAR 1). The assumed cause for the airspace closure was an extreme weather condition, which led to a closed air space. An airspace closure triggered sending a DNOTAM via the SWIM infrastructure that was consequently received by all ATC systems that subscribed for receiving such information. The ATC system in charge then recalculated the trajectory and updated the shared Flight Information. In a further step, the destination airport calculated an updated ETA, which was then sent via the SWIM infrastructure. A messaging gateway received these updates and sent text messages with the revised ETA for the affected flights to subscribers in the audience.

SWIM allows a change of the operational process as shown in Figure 4. The involved actors get the information almost in real-time as soon as the DNOTAM is published. This information available in combination with the planned flights allows the SWIM-enabled applications to calculate the rerouting fast and offer the controllers the possibility to choose between different alternative routes (which are calculated semi-automatically). Even the information to the customer can be published near to real time as drawn. This circumstance allows a faster processing of the two flights leading to quicker reroutes of the flights. Chapter 4 shows the information stream in detail, from the published DNOTAM by the European AIS Database (EAD) to the ACC and other involved SWIM clients. Since all the stakeholders involved have subscribed the published information, the ACC centres get the information almost in real-time. New SWIM-enabled applications will process this information for the controllers to allow a coordinated way of collaborative decision. This will not only save time but also fuel costs.

2.4 BEST enabled Operational Method

Today's problem of ATM information consumers is that most of the time filtering and composition are hard coded in the applications and therefore are not reusable. The semantic container technique envisioned in BEST forms information needed for an operational scenario as a data set (e.g.: filtering, composition, quality attributes). It automatically identifies the missing processing steps to generate a semantic container that fulfils the specification needs. The BEST prototype will be used to demonstrate that the exchange and management of ATM information, as foreseen by the SWIM concept, can be even further enhanced by adding support for the aggregation and filtering of the data for specific purposes.

BEST's semantic container focuses on enriching data into a set of data items labelled with semantic meta-data concerning, for example, freshness, quality aspects, localization, and time (Schuetz, Neumayer, & Schrefl, D2.1 Techniques for ontology-based data description and discovery in a decentralized SWIM knowledge base, 2018). SWIM applications can use this information to be more efficient. Generic filtering and clustering of SWIM data will help SWIM developers to reduce redundancies. Messages based on AIXM (Eurocontrol, Aeronautical Information Exchange Model (AIXM), 2016), IWXXM (Eurocontrol, Weather Information Exchange Model (WXXM), kein Datum) and FIXM (Eurocontrol, Flight Information Exchange Model (FIXM), 2016) such as DNOTAMs, TAFs, METARs, SIGMETs and flight plans are prepared as BEST semantic containers with labels which can be further processed. Future SWIM applications will only need to focus on the necessary operational specific filtering and prioritizing data based on operational rules. The BEST approach enables a generic way of filtering time, location and additional semantic aspects such as the quality of data.

The semantic container uses semantic labels to enrich the information about data sets (Neumayr, et al., 2017). The semantic labelling enhances the existing data with additional information in order to provide generic grouping or filtering based on exchange model specifics (AIXM, FIXM and IWXXM), time, location, and quality metrics. This approach allows any SWIM data provider or consumer to benefit from the BEST approach. SWIM applications will retrieve semantic containers prepared using filtering, and will only have to perform operational specific processing to use them for a defined purpose. This will lead to less redundant implementations since the generic part of those applications does not have to be implemented over and over again for each different operational process. With BEST in place only operational specific filtering and prioritizing will be processed by the application, a pre-structuring and quality information of/on the data will be provided via the BEST semantic container approach. BEST is envisioned to be integrated to the SWIM registry in the future, to distribute semantic containers to all SWIM users and content creators (see Figure 5).

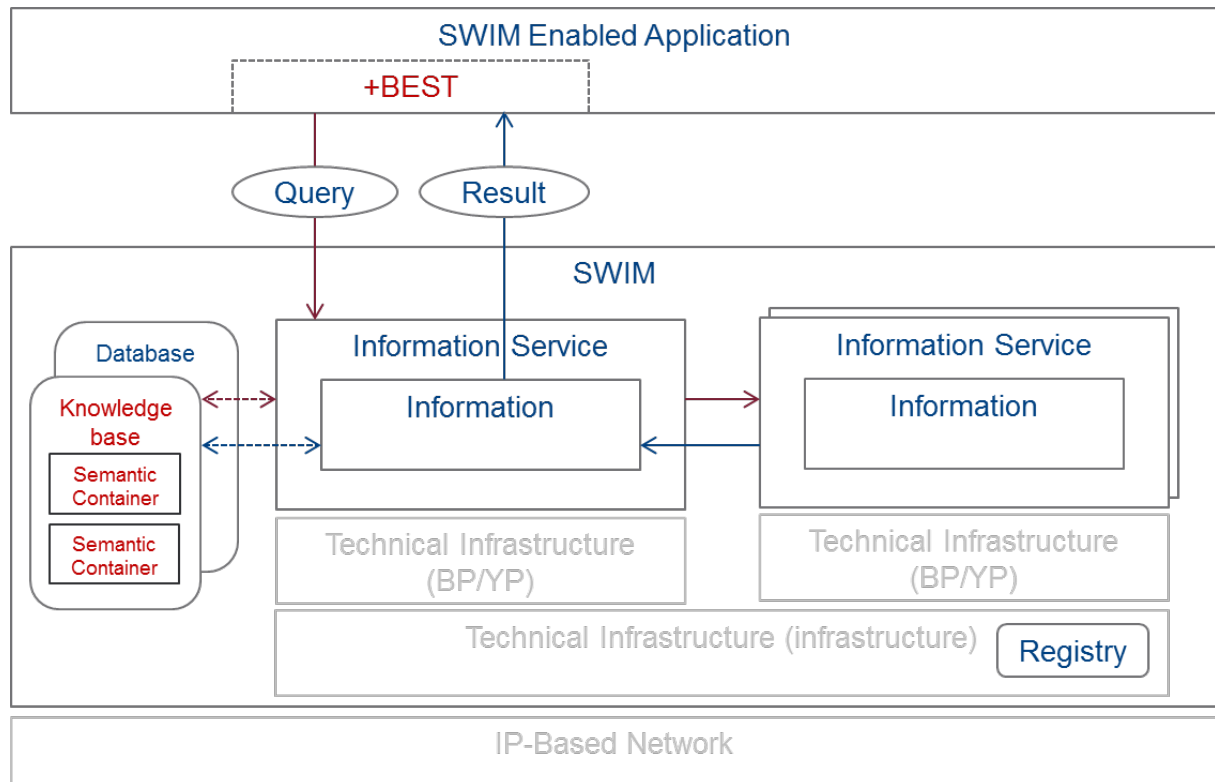

Figure 5: How Semantic Containers fit in to SWIM

Semantic containers help to describe the base information that a service instance works on and allows for the automatic determination of the generalization/subsumption relationships between these sets of data/information as shown in Figure 5. Semantic containers allow describing the data/information that a service invocation/call receives as input and returns as output (see Figure 5).

Developing value-added data services and applications in SWIM will encompass finding, selecting, filtering and composition of data from different sources (Neumayr, et al., 2017). Without a semantic description of the information, the data logic will likely be hard-coded in applications and service implementations, intertwined with business and presentation logic, which hinders reuse. In this regard, SWIM can be imagined as a gigantic whiteboard where different authorities write data, making it difficult for stakeholders to focus on the data relevant for a specific purpose in the needed quality. The complexities of the data logic will likely absorb most of a developer's attention, restraining them from developing novel applications and value-added services. More detailed information about what a semantic container is and how they are used for data description and discovery can be found in the deliverable D2.1 (Schuetz, Neumayer, & Schrefl, D2.1 Techniques for ontology-based data description and discovery in a decentralized SWIM knowledge base, 2018).

2.4.1 Semantic Container Derivation Chains

In Deliverable D2.1 the derivation chains of activities and semantic containers are defined (Schuetz, Neumayer, & Schrefl, D2.1 Techniques for ontology-based data description and discovery in a decentralized SWIM knowledge base, 2018). Figure 6 describes all possible chains from a high-level perspective. Through filtering, enrichment, combination and composition of information several derivation states can be calculated. To keep the figure as readable as possible, it does not show

component containers, physical containers (allocation of logical containers), versions and administrative metadata. It gives a good overview of how a semantic container can be generated.

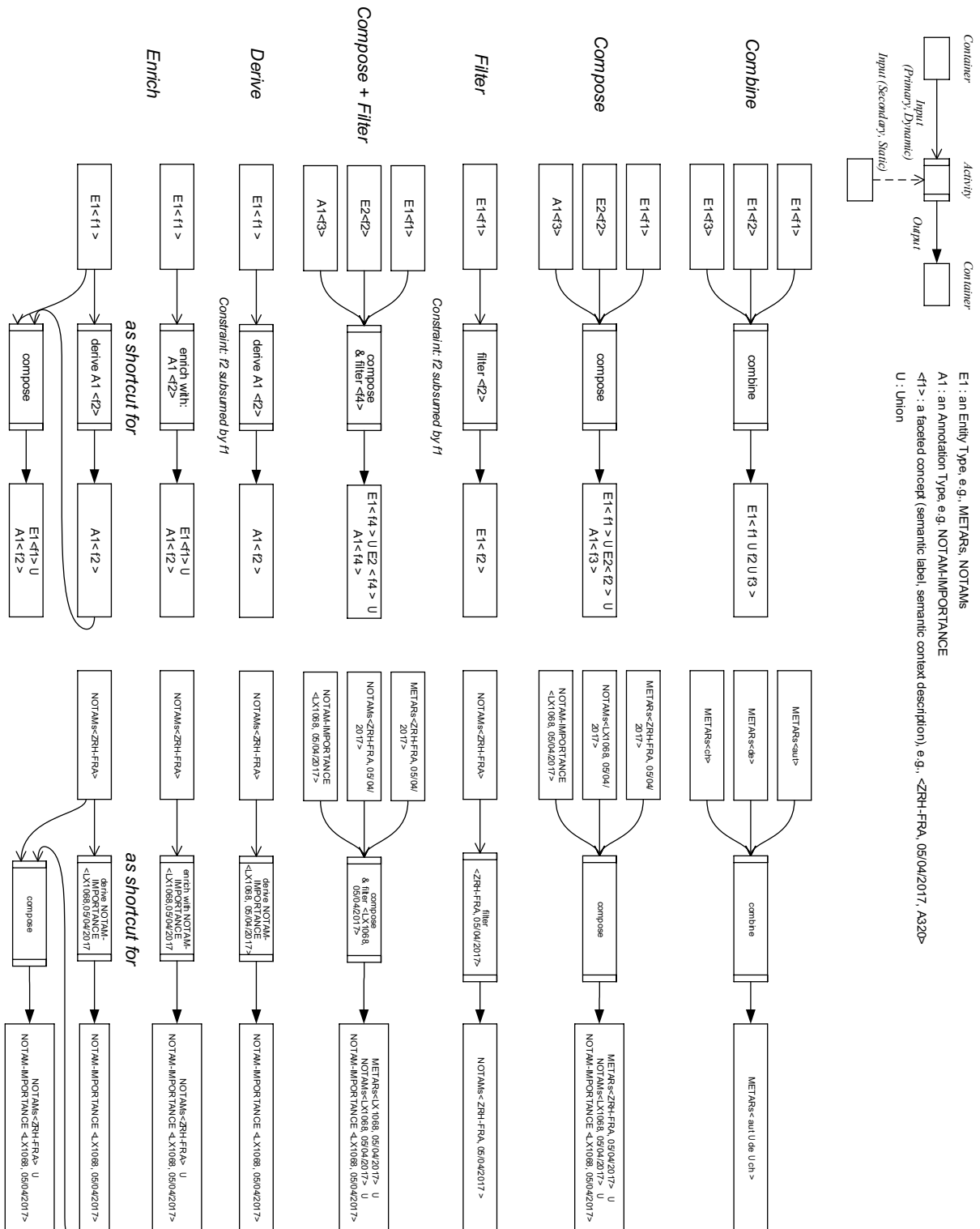

Figure 6: Semantic Container derivation chains with concrete examples.

3 Prototype Use Cases

It is easy to mix up the definitions of use case and use case scenario. A use case represents the actions that are required to enable or abandon a goal. A use case has multiple “paths” that can be taken by any user at any one time. A use case scenario is a single path through the use case.

Integrated Digital Briefing was selected as the SWIM-based application and operational scenario, since it was already mature enough to work with. It involves exchanges using Information standardized by SWIM. All the presented use cases in this chapter and the use case scenarios in chapter 4 are fitting to this preselection. The actors of the use cases are listed below in Figure 7. In most cases, the actors interact with systems that host services, which perform most of their work automatically. As such, Actors are used to represent an operational instance which is responsible for the service, or it is authorized to use it, or acts as an intermediary for the final user of the service. The following sections use operational terms explained in *APPENDIX A: Anatomy of a Flight*, *APPENDIX B: Operational Scenario*, and *APPENDIX C: SWIM Services*.

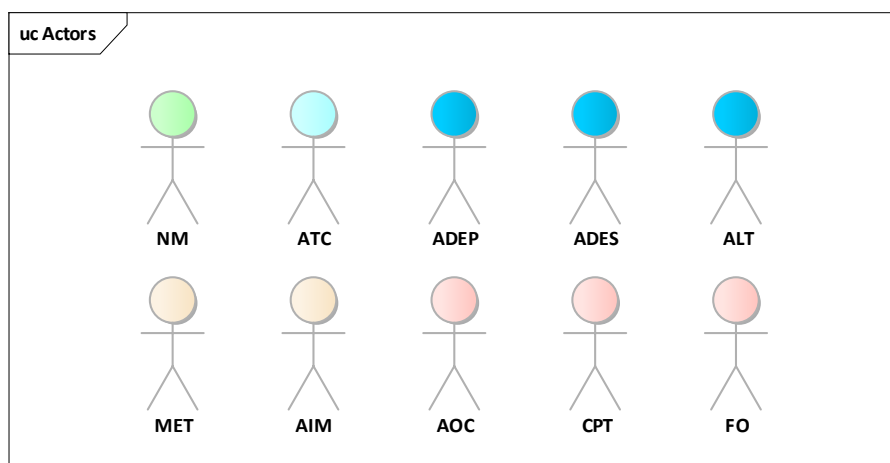

Figure 7: Use Case Actors

- ADEP Departure Airport Operator
- ADES Destination Airport Operator
- ALT Alternate Airport Operator
- AOC Airline Operations Centre
- ATC Air Traffic Control Operator
- NM Network Management Operator
- AIM Aeronautical Information Management (Data Provider)
- MET Meteorological Information (Data Provider)
- CPT Captain (Operating Pilot)
- FO First Officer (Operating Co-Pilot)

The operational steps are supported by data services that are listed on the next page.

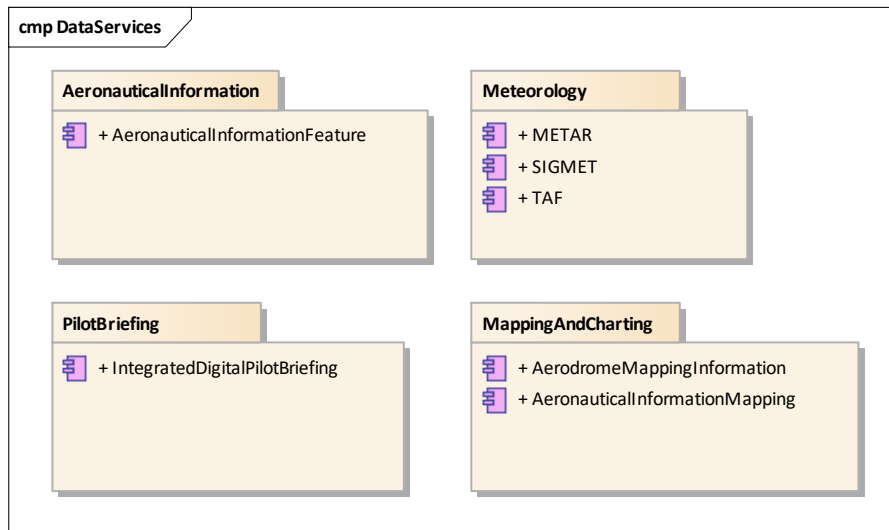

Figure 8: SWIM Services applied for the Use Cases

The services are SWIM compliant and modelled based on SESAR's Information Services Reference Model (Häggström, et al., 2016). The prototype use cases define interactions between an actor and a system or between two systems to achieve an operational goal such as transmitting a set of data from a provider to a consumer. The use cases do not focus on specific traffic conditions or airspace configuration but exemplarily show how some of the current operations (e.g. during pre-flight or en-route) could be improved by the Semantic Container approach in combination with SWIM. The use cases depict a typical situation for a couple of flights in different flight phases (see APPENDIX A: Anatomy of a Flight) specifically focusing on a generic flight from ADEP "A" to ADES "B". Each use case is presented in two versions:

SWIM: such a Use Case is implemented as required by SWIM compliance rules without any BEST specific modifications. The services involved in each use case are used by consumers directly or by means of a message broker, as specified by SWIM requirements.

BEST: such a Use Case is implemented as required by SWIM compliance rules, but also including BEST specific components. The services involved are not communicating directly or by means of a broker with their consumers, but a layer of BEST semantic containers is interposed between the service and consumers to handle functions introduced by BEST. The services and consumers are oblivious of the interposed semantic container layer, while the service interfaces realized are the same as in the SWIM version of the Use Case, thus eliminating the necessity of modifying existing services and consumer implementations.

3.1 Use Case: Aeronautical Information

This Use Case is linked to the following scenario steps defined in following sections:

- 4.1.1.7 Request ePIB data by AOC from ePIB Service and
- 4.2.1.8 Request ePIB data by AOC from ePIB Service

3.1.1 SWIM Use Case: Retrieve Aeronautical Information Feature

The SWIM version of the Use Case is supported by the Aeronautical Information Feature Service (AIFS – Annex 11.1) through its service interface with the same name. The service consumer is connecting to the provider service directly and invokes operations provided by the service interface. In this case, with AIFS being a specialization of the OGC standardized Web Feature Service (WFS), the consumer uses the operation GetFeature to retrieve the information on any Aeronautical Feature known to the AIFS.

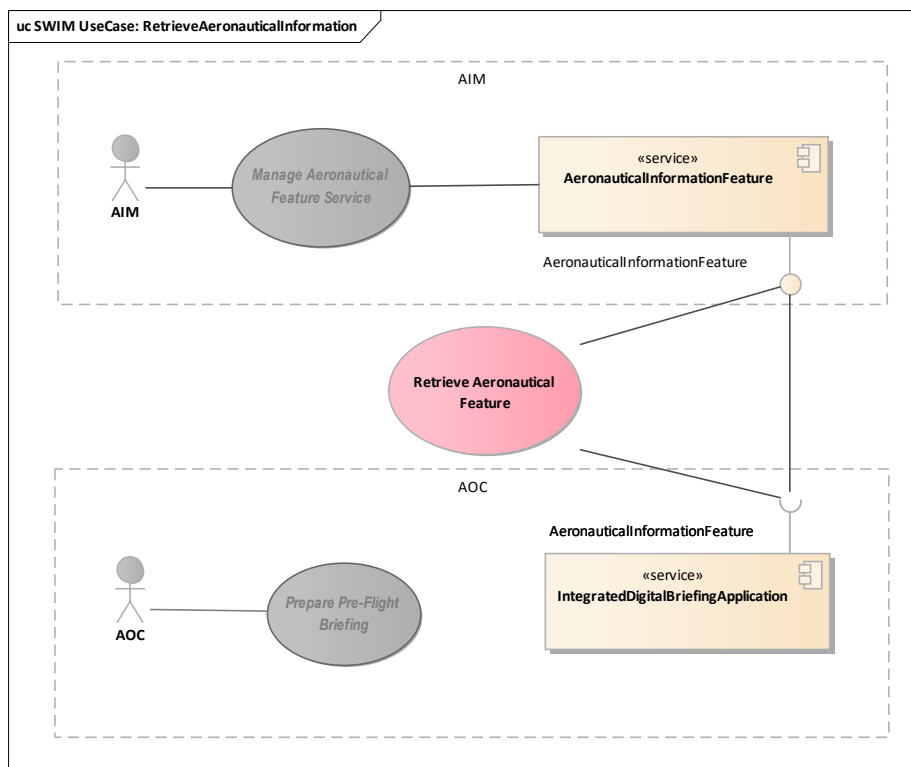

Figure 9: SWIM Use Case: Retrieve Aeronautical Information Feature

3.1.2 BEST Use Case: Retrieve Aeronautical Information Feature

The BEST version of the Use Case is adding the BEST semantic container service support into the process of retrieving the needed Aeronautical Information Feature data. The service consumer is not sending requests to the Aeronautical Information Feature Service directly, but to the BEST semantic container service instance(s) assigned to handle the data needs of the consumer for specific situations. The semantic container(s) implement(s) and require the same service interfaces as the original service, thus the consumer doesn't have to differentiate between the requests. Hidden from the service consumer are the background processes that decide whether to use semantic container cached data or request fresh data from the original service.

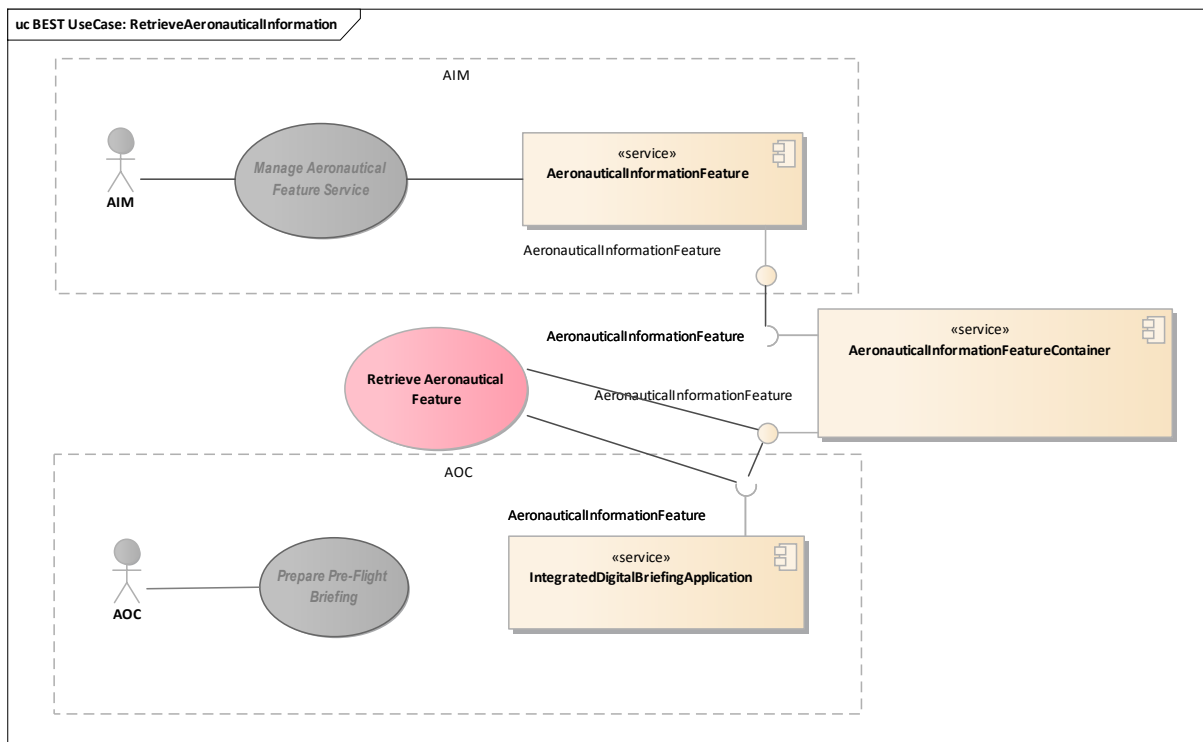

Figure 10: BEST Use Case: Retrieve Aeronautical Information Feature

3.1.2.1 Semantic Container Aeronautical Information

Figure 11 shows the derivation chain to derive an *Aeronautical Features Container* for a specific *Flight Number* and *Date* consisting of a container for Aeronautical Features for <ADEP-ADES> for the given date together with a container with annotations Aeronautical Features Priorities for the given flight number and date. First, activity “Combine Aeronautical Features for Specific Area” combines elementary containers “Aeronautical Features <Region X> Provider Y” for different regions from different providers into a homogeneous composite container “Aeronautical Features <Area 1>”. This homogeneous composite container consists of elementary containers. Each elementary container may be traced back to a single source. For example, elementary container “Aeronautical Features <Region 1>” in composite container “Aeronautical Features <Area 1>” can be traced back to elementary container “Aeronautical Features <Region 1> Provider 1”. Being able to trace back the contents of an elementary container to a single source and a single derivation path fosters the ability of users and software to assess the data quality of its content. It further simplifies the maintenance of derived containers (i.e., keeping the derived container up-to-date with its sources).

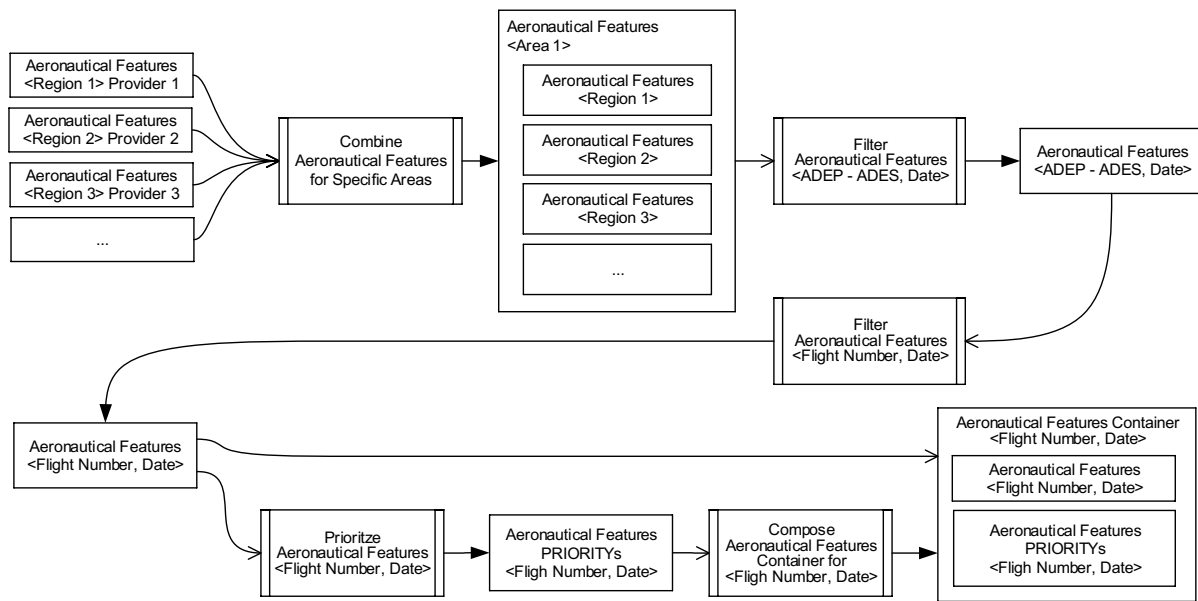

Figure 11: Generic derivation chain of an Aeronautical Information Semantic Container

The next activity “Filter Aeronautical Features <ADEP-ADES, Date>” has homogeneous composite container “Aeronautical Features <Area 1>” as input and filters its contents for aeronautical features that are relevant for flight from ADEP to ADES on the given date. The output of this filter operation is homogeneous composite container “Aeronautical Features <ADEP-ADES, Date>” which has components (not shown for conciseness) such as “Aeronautical Features <Region 1, ADEP-ADES, Date>”, each of which can be traced back to a single source, e.g. to “Aeronautical Features <Region 1>” in “Aeronautical Features <Area>” and to “Aeronautical Features <Region 1> Provider 1”. Same procedure is applied by the filter activity “Filter Aeronautical Features <Flight Number, Date>”. This part of the derivation chain is of course optional.

The next activity is “Prioritize Aeronautical Features <Flight Number, Date>” which derives output “Aeronautical Features PRIORITYS <Flight Number, Date>” which associates the aeronautical features with a priority (importance) with regard to the given flight number and date. This is again a homogeneous composite container, which has components (not shown for conciseness) such as “Aeronautical Features PRIORITYS<Region 1, Flight Number, Date>”, each of which can be traced back to a single source, e.g. to “Aeronautical Features <Region 1, Flight Number, Date>”, in turn to “Aeronautical Features <Region 1>” in “Aeronautical Features <Area>” and to “Aeronautical Features <Region 1> Provider 1”. Being able to trace back each elementary container to a single source simplifies maintenance. For example, when the content of “Aeronautical Features <Region 1> Provider 1” changes, only container “Aeronautical Features PRIORITYS<Region 1, Flight Number, Date>” has to be updated, the other components, such as “Aeronautical Features PRIORITYS<Region 2, Flight Number, Date>”, are left unchanged.

Finally, activity “Compose Aeronautical Features Container for <Flight Number, Date>” composes container “Aeronautical Features < Flight Number, Date>” and container “Aeronautical Features PRIORITYS <Flight Number, Date>” into heterogeneous composite container “Aeronautical Features Container <Flight Number, Date>”.By using the intermediary semantic container benefits in regard to availability (section 3.6.2) and decreased network load (section 3.6.3) can be realized.

3.2 Use Case: MET Information

This Use Case is linked to the following scenario steps defined in following sections:

- 4.1.1.1 Publication of METAR, TAF for YSSY, OMDB by MET
- 4.1.1.2 Publication of Severe Turbulence SIGMET for OMAE FIR by MET
- 4.1.1.10 Publish VA SIGMET for WIIF, WAAF FIRs by EUMETNET Service
- 4.1.1.13 Publication of METAR for OMDB by NCMS MET Service
- 4.2.1.1 Publication of METAR/TAF for OMDB by NCMS MET Service
- 4.2.1.2 Publication of METAR, TAF for LOWW, LOWL by EUMETNET
- 4.2.1.3 Publication of Severe Icing SIGMET for LOWW TMA/ACC by EUMETNET
- 4.2.1.11 Publication of Turbulence SIGMET for LRBB by EUMETNET
- 4.2.1.12 Publication of Thunderstorm SIGMET for LHCC by EUMETNET

The following specializations of the use cases are identified:

- Publish METAR
- Subscribe METAR
- Publish TAF
- Subscribe TAF
- Publish SIGMET
- Subscribe SIGMET

3.2.1 SWIM Use Case: Subscribe/Publish MET Information

The SWIM version of the Use Case is supported by the METAR, TAF and METHazardEnrouteObservation (cf. Annex 11.4) services by use of the publish/subscribe MEP. Each service provides a service interface for subscribing to the service and requires from subscribers to implement an interface for publishing. The data exchange model used is IWXXM. The consumers/subscribers of METAR, TAF, SIGMET connect to the service either directly (or by means of a message broker). The consumer receives all the information published by the service.

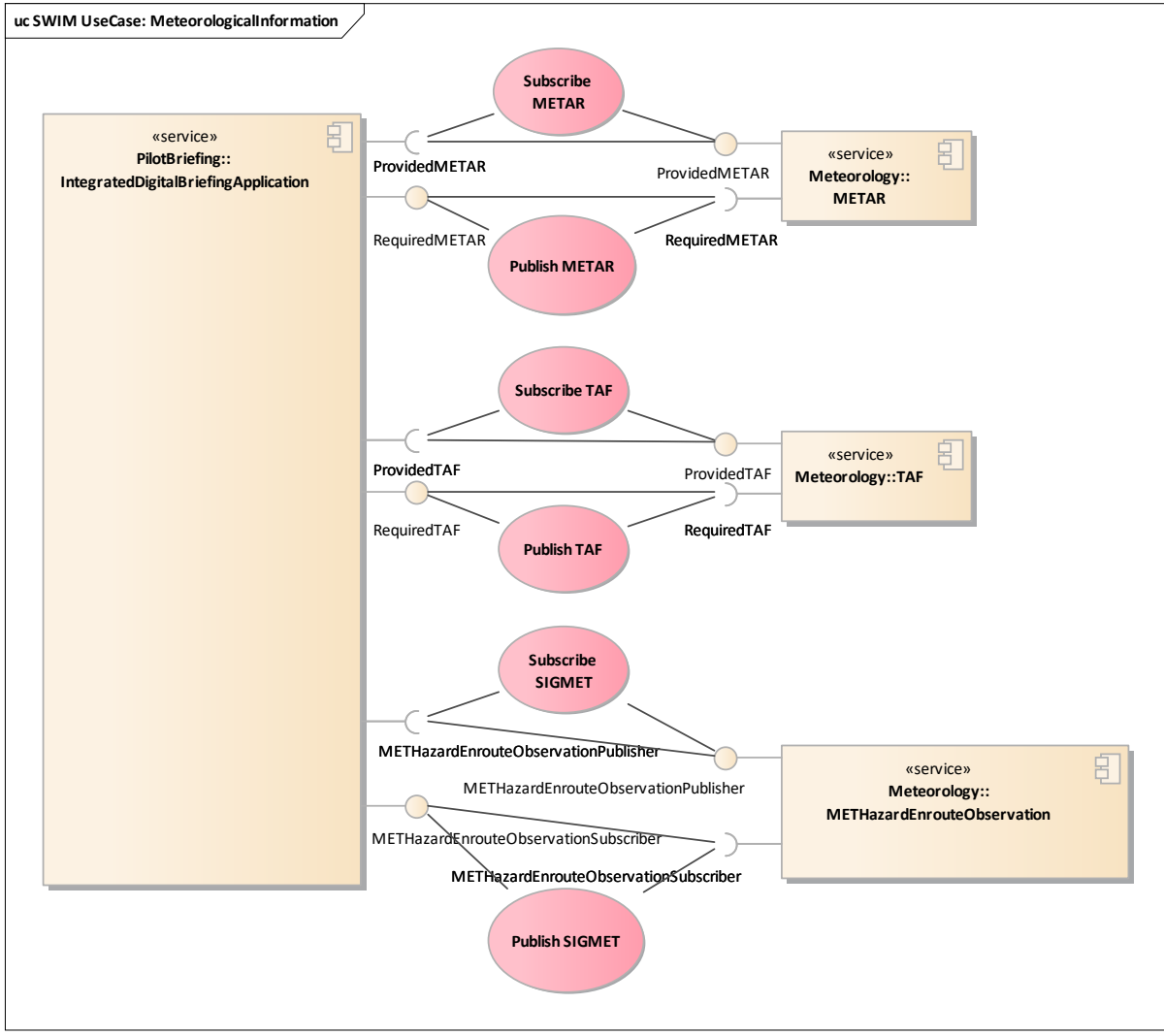

Figure 12: SWIM Use Case: Subscribe/Publish MET Information

3.2.2 BEST Use Case: Subscribe/Publish MET Information

The BEST version of the Use Case is also supported by the METAR, TAF and METHazardEnrouteObservation services by use of the publish/subscribe MEP. The service consumers/subscribers are not connecting and/or subscribing to the information providers directly anymore. Instead, they are connecting and/or subscribing to various BEST semantic containers that maintain/retain the information concerning their area of responsibility. The semantic containers make the decision on whether to (re-) publish information to their subscribers. The consumers are oblivious to the interposed semantic container(s).

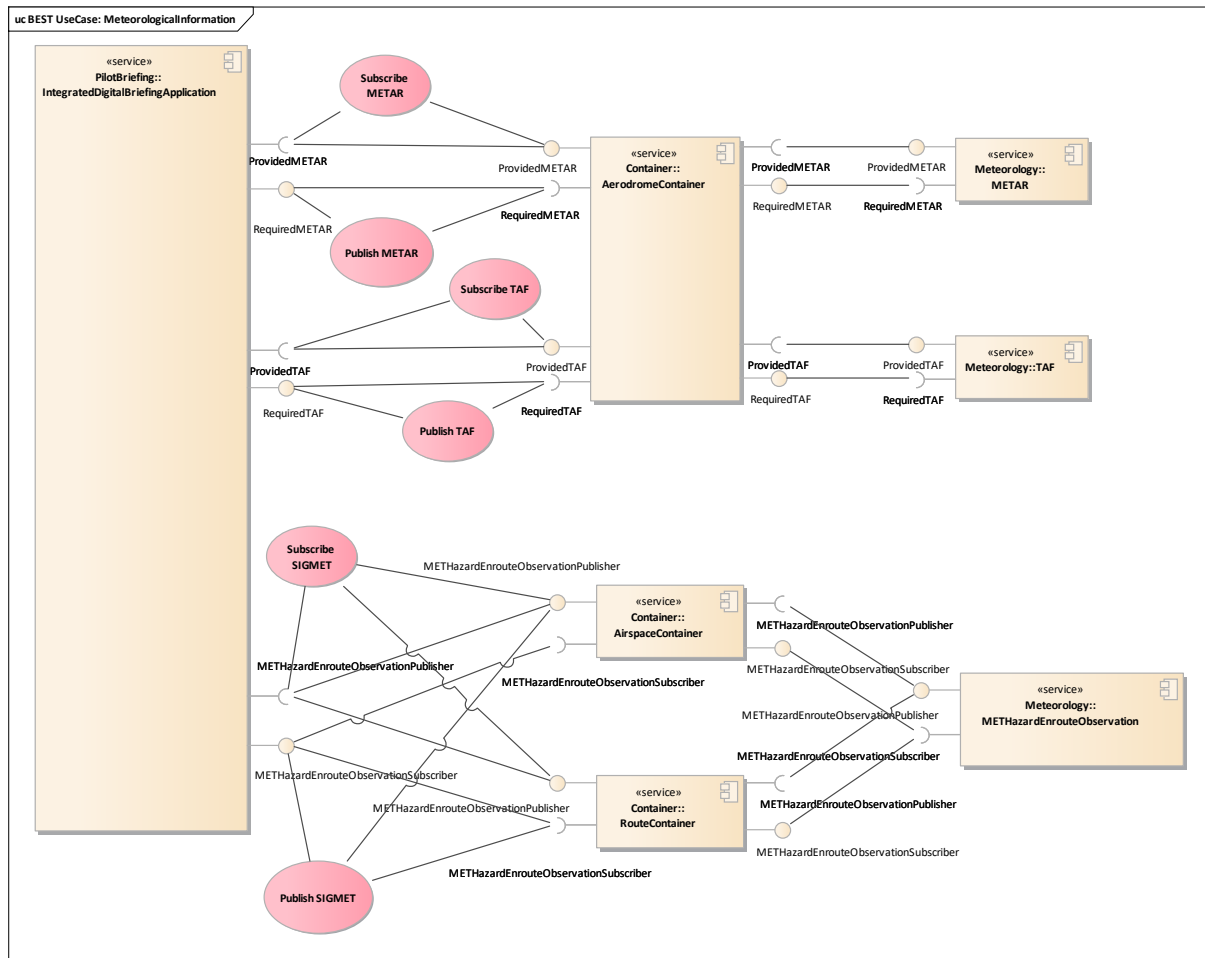

Figure 13: BEST Use Case: Subscribe/Publish MET Information

3.2.2.1 Semantic Container - MET Aerodrome

Figure 14 models the derivation of an “Compose & Filter MET Airport Container” for a specific combination of “<Flight Number, Date, Aircraft Type>” which contains relevant METARS and TAFs relevant for a specific Flight (identified by Flight Number and Date) filtered by a given Aircraft Type.

Activity “Combine METARs for Specific Areas” combines METARs from different providers into a homogeneous composite container “METARs <Area 1>”. Activity “Filter METARs <ADEP-ADES, Date>” filters for METARs relevant to a given set of aerodromes relevant for this flight. The container “AERODROMES relevant for <ADEP-ADES, Date>” is a secondary input to the activity while “METARs <Area 1>” is its primary input. Distinguishing inputs into primary and secondary inputs allows tracing back each result to a single source. Further, primary sources are dynamic (their content may change) while secondary inputs are considered static (their content does not change). This restriction simplifies the maintenance of derived containers. The output of this filter operation is homogeneous composite container “METAR Container <ADEP-ADES, Date>”.

Likewise, activity “Combine TAFs for Specific Areas” combines TAFs from different providers resulting in homogeneous composite container “TAFs <Area 1>” which are subsequently filtered resulting in homogeneous composite container “TAF Container <ADEP-ADES, Date>”.

Activity “Compose & Filter METAR/TAF for <Flight Number, Aircraft Type, Date>” composes “TAF Container <ADEP-ADES, Date>” and “METAR Container <ADEP-ADES, Date>” into a heterogeneous composite container “MET Airport Container <Flight Number, Date, Aircraft Type>”.

The activity takes “Rules relevant for a specific <Aircraft Type>” as secondary input and derives METAR Annotations and TAF annotations which are composed together with its primary input into heterogeneous composite container “Enriched MET Airport Container <Flight Number, Date, Aircraft Type>”.

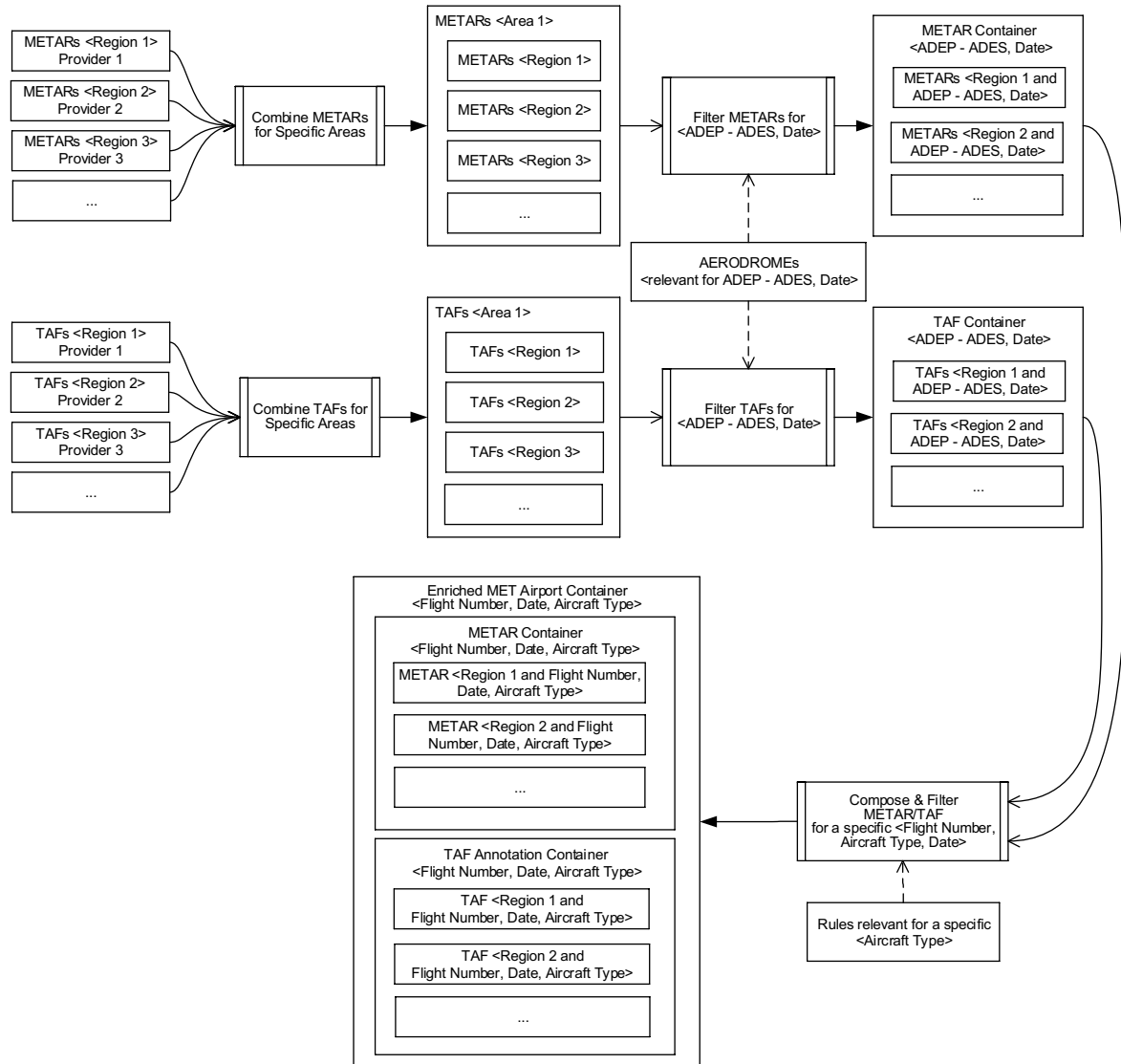

Figure 14: Generic derivation chain of a MET Aerodrome Semantic Container

3.2.2.2 Semantic Container - MET Airspace

Figure 15 shows the derivation of a heterogeneous composite “Annotated SIGMET Airspace Container” specific to “<ADEP-ADES, Date>”.

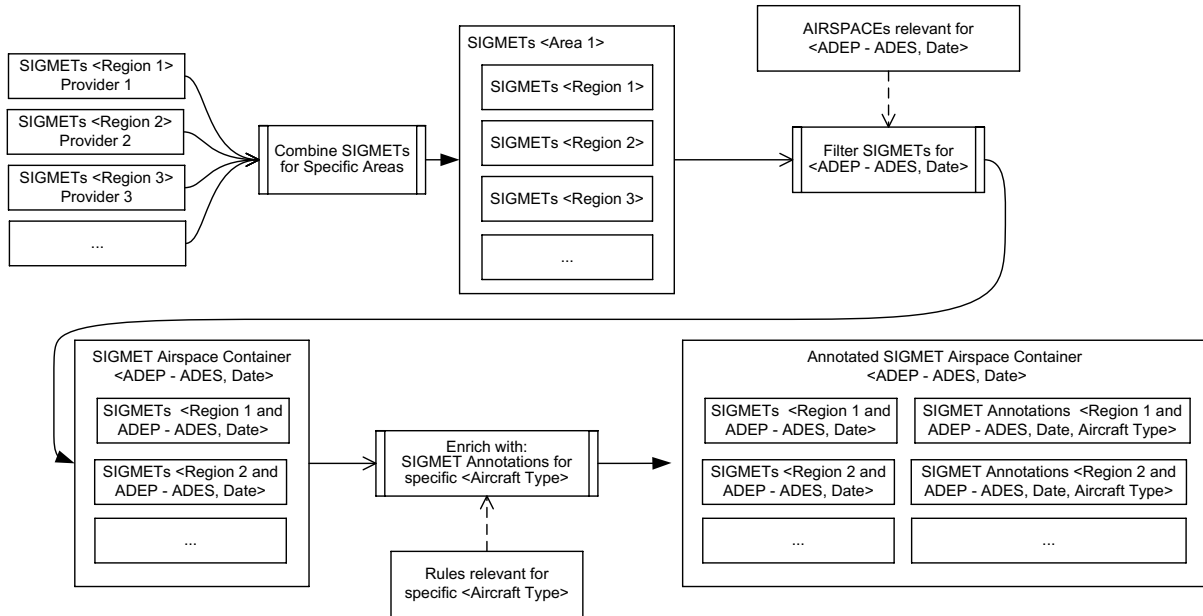

Figure 15: Generic derivation chain of a MET Airspace Semantic Container

First, activity “Combine SIGMETs for Specific Areas” combines SIGMET containers from different regions from different providers, such as elementary container “SIGMETs <Region 1> Provider 1”, into homogeneous composite container “SIGMETs <Area 1>”.

Activity “Filter SIGMETs for <ADEP-ADES, Date>” takes “AIRSPACES relevant for <ADEP-ADES, Date>” as secondary/static input to filter its primary input “SIGMETs <Area 1>” to produce container “SIGMET Airspace Container <ADEP-ADES, Date>”.

Activity “Enrich with SIGMET Annotations for specific <Aircraft Type>” has “SIGMET Airspace Container <ADEP-ADES, Date>” as primary input and “Rules relevant for specific <Aircraft Type>” as secondary/static input to derive “SIGMET Annotations <Region 1 and ADEP-ADES, Date, Aircraft Type>” and “SIGMET Annotations <Region 2 and ADEP-ADES, Date, Aircraft Type>” and compose it together with its primary input into heterogeneous composite container “Annotated SIGMET Airspace Container <ADEP-ADES, Date>”.

3.2.2.3 Semantic Container - MET Route

Figure 16 shows the derivation of a heterogeneous composite “Annotated SIGMET Route Container” specific to “<ADEP-ADES, Date>”. This derivation chain is similar to the derivation of “Annotated SIGMET Airspace Container” with the difference that activity “Filter SIGMETs for <ADEP-ADES, Date>” filters with regard to relevant airspaces as specified by secondary/static input “AIRSPACES relevant for <ADEP-ADES, Date>”.

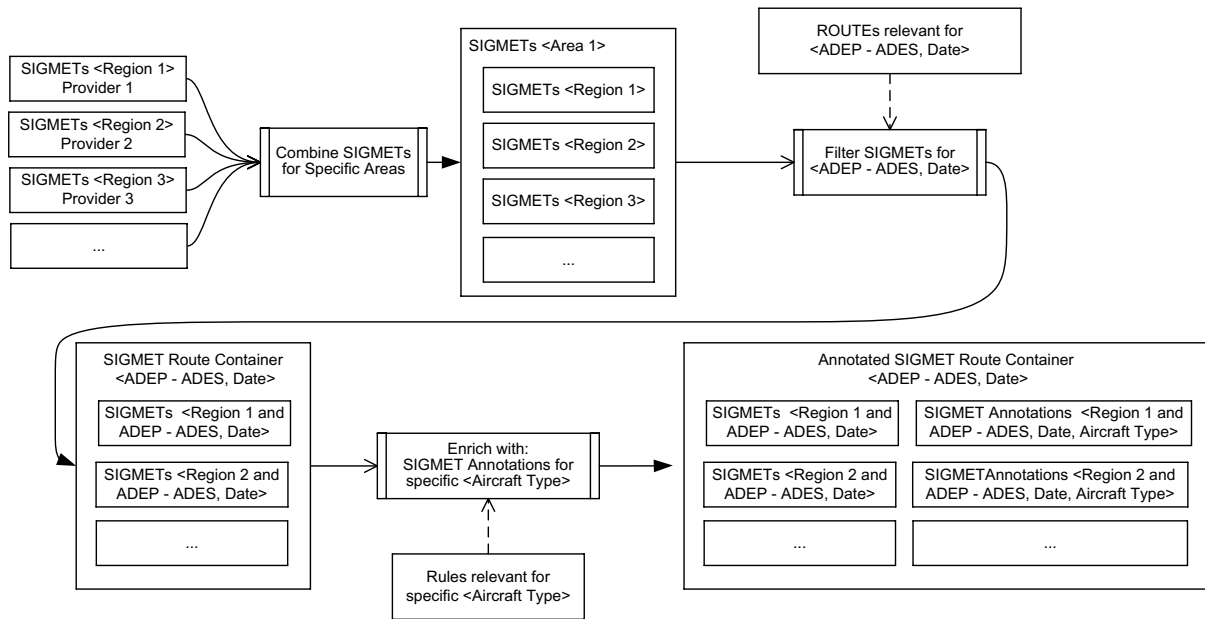

Figure 16: Generic derivation chain of a MET Route Semantic Container

By using semantic containers in this use case benefits in regard to defined quality (section 3.6.1) and availability (section 3.6.2) can be realized.

3.3 Use Case: Digital NOTAM

This Use Case is linked to the following scenario steps defined in following sections:

- 4.1.1.3 Publication of DNOTAM (NAV.UNS and SAA.ACT) by AIM
- 4.1.1.11 Publish DNOTAM (RTE.CLS) by AIM
- 4.2.1.4 Publication of DNOTAM (RTE.CLS) by GCAA
- 4.2.1.14 Publication of DNOTAM (RWY.CLS) by ACG

3.3.1 SWIM Use Case: Request/Subscribe/Publish Digital NOTAM

The SWIM version of the Use Case is supported by the Aeronautical Information Notification Service (AINS – Annex 11.2) by use of the request/response and publish/subscribe MEPs. The AINS provided interface supports both MEPs. The data exchange model used is AIXM5.1 and its extension Digital NOTAM. The consumers connect to the AINS directly when request/response is used and directly or through a broker service when publish/subscribe is used.

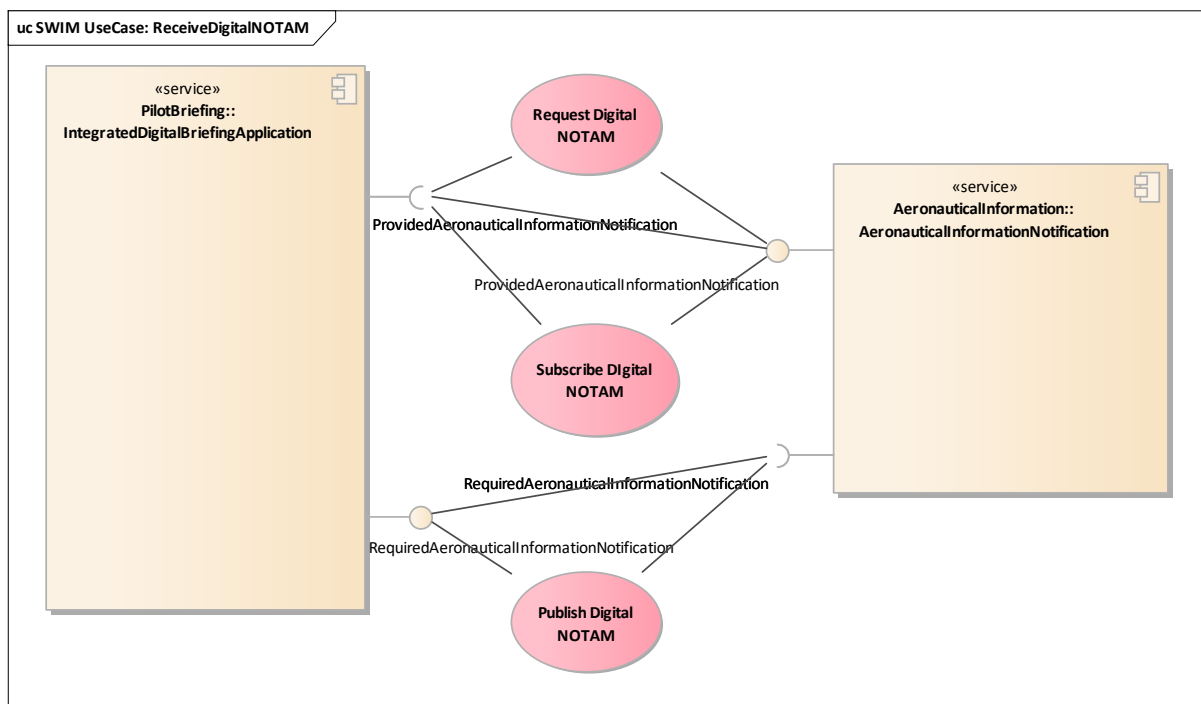

Figure 17: SWIM Use Case: Request/Subscribe/Publish Digital NOTAM

3.3.2 BEST Use Case: Request/Subscribe/Publish Digital NOTAM

The BEST version of the Use Case is also supported by the Aeronautical Information Notification Service (AINS) by use of the request/response and publish/subscribe MEPs. The service consumers/subscribers are not connecting and/or subscribing to the information providers directly anymore. Instead, they are connecting and/or subscribing to various semantic containers that maintain/retain the information concerning their area of responsibility that could be provided by a semantic container service. The semantic containers make the decision on whether to (re-) publish information to their subscribers. The consumers are oblivious to the interposed semantic container(s).

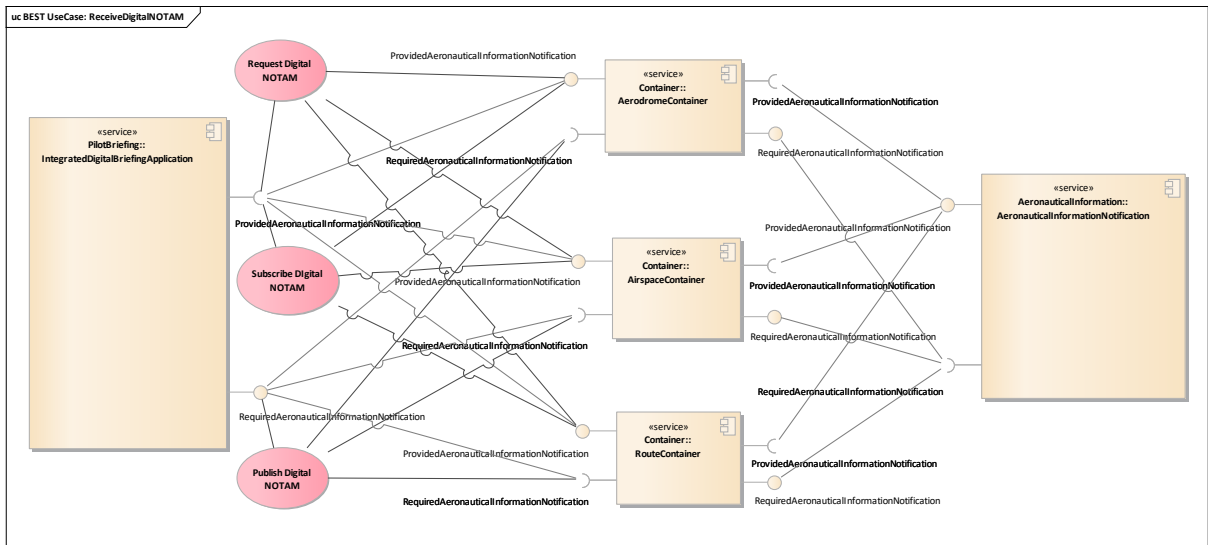

Figure 18: BEST Use Case: Request/Subscribe/Publish Digital NOTAM

3.3.2.1 Semantic Container - DNOTAM Aerodrome

Figure 19 shows the derivation of a heterogeneous composite container “DNOTM Aerodrome Container <Flight Number, Date>”. Activity “Combine DNOTAMs for Specific Areas” gets DNOTAMs for different regions from different providers and combines them into homogeneous composite container “DNOTAMs <Area 1>”. Activity “Filter DNOTAMs <ADEP-ADES, Date>” with static input “AERODROMES relevant for <ADEP-ADES, Date>” produces homogenous composite container “DNOTAMs <ADEP-ADES, Date>” (its components are elementary containers which are not depicted in Fig XXX). Activity “Enrich with Prioritize DNOTAMs <Flight Number, Date>” derives DNOTAM priorities (representing their importance) with regard to the given Flight Number and Date.

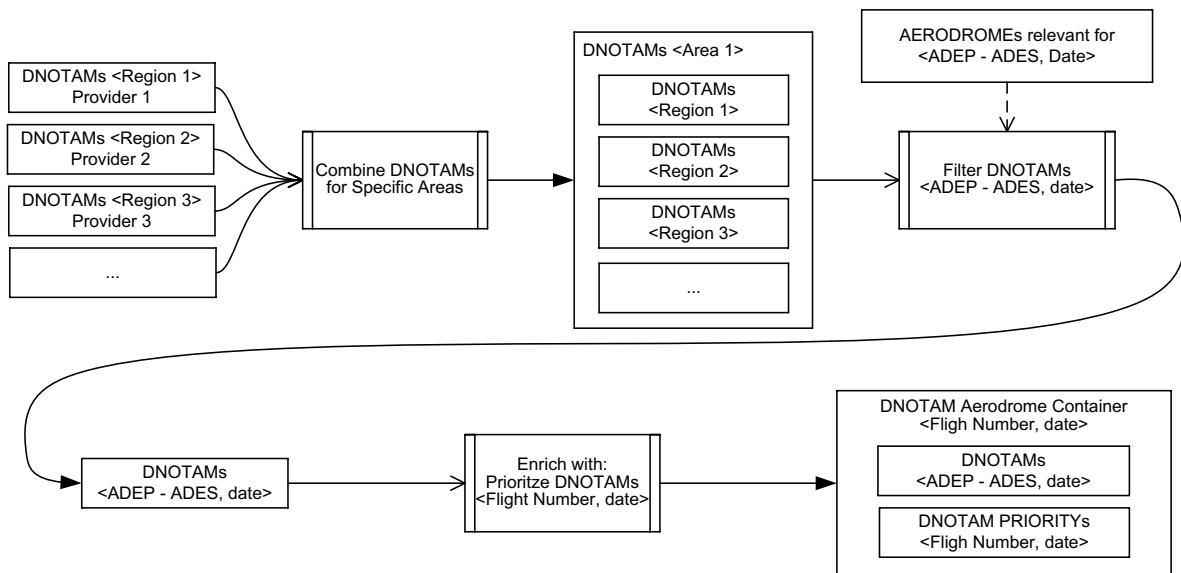

Figure 19: Generic derivation chain of a DNOTAM Aerodrome Semantic Container

3.3.2.2 Semantic Container - DNOTAM Airspace

Figure 20 shows the derivation of a heterogeneous composite container “DNOTM Airspace Container <Flight Number, Date>”. It is similar to the derivation of container “DNOTM Aerodrome Container <Flight Number, Date>” with the difference that activity “Filter DNOTAMs <ADEP-ADES, Date>” filters with regard to relevant airspaces as specified by secondary/static input “AIRSPACES relevant for <ADEP-ADES, Date>”.

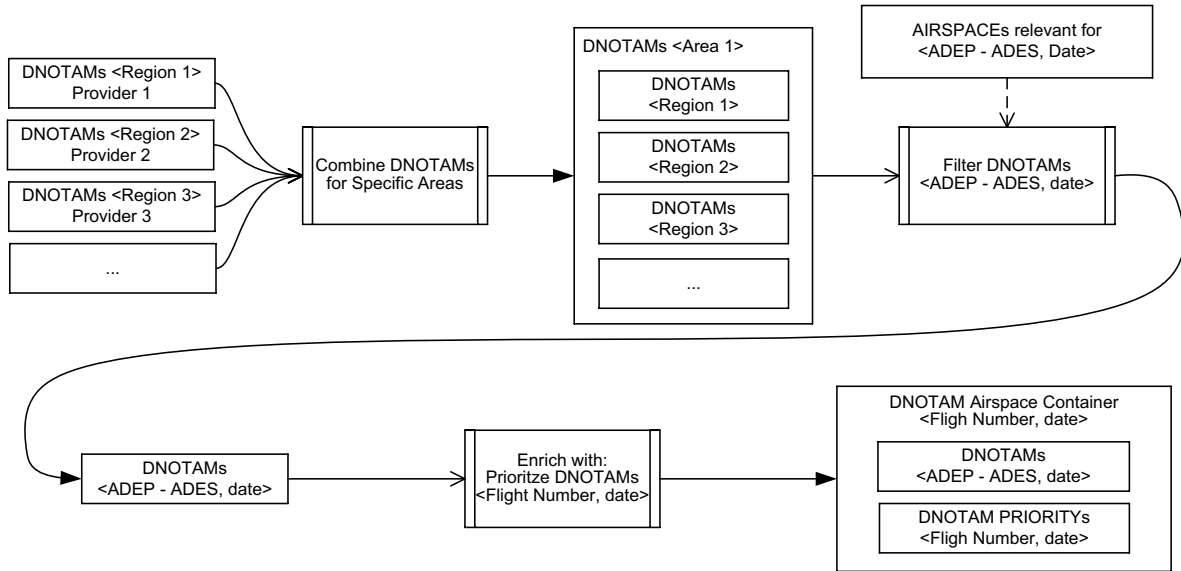

Figure 20: Generic derivation chain of a Semantic Container - DNOTAM Airspace

3.3.2.3 Semantic Container - DNOTAM Route

Figure 21 shows the derivation of a heterogeneous composite container “DNOTM Route Container <Flight Number, Date>”. It is similar to the derivation of container “DNOTM Aerodrome Container <Flight Number, Date>” with the difference that activity “Filter DNOTAMs <ADEP-ADES, Date>” filters with regard to relevant routes as specified by secondary/static input “ROUTES relevant for <ADEP-ADES, Date>”.

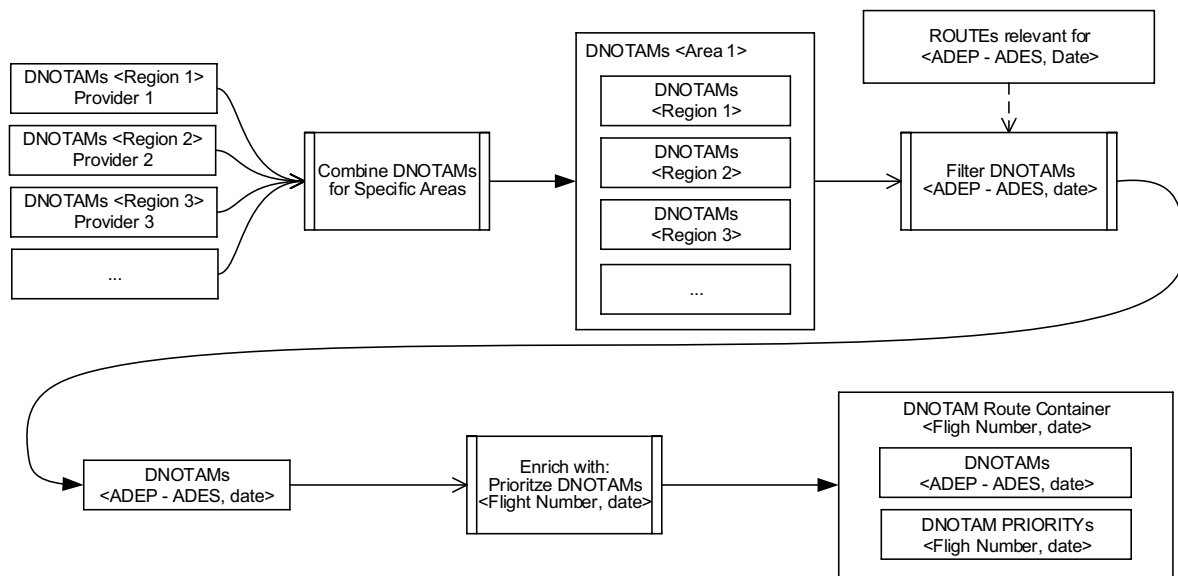

Figure 21: Generic derivation chain of a Semantic Container - DNOTAM Route

By using semantic containers benefits in regard to defined quality (section 3.6.1), availability (section 3.6.2) and decreased network load (section 3.6.3) can be realized.

3.4 Use Case: Flight Plan

This Use Case is linked to the following scenario steps defined in following sections:

- 4.1.1.4 Publish FPL by AOC for ATC
- 4.1.1.5 Publish FPL by ATC for NM
- 4.1.1.6 Publish FPL in SWIM by NM
- 4.2.1.5 Publish FPL by AOC for ATC (GCAA)
- 4.2.1.6 Publish FPL by ATC (GCAA) for NM
- 4.2.1.7 Publish FPL in SWIM by NM

3.4.1 SWIM Use Case: Request/Subscribe/Publish Flight Plan

The SWIM version of the Use Case is supported by the Flight Plan Distribution Service by use of the request/response and publish/subscribe MEPs. The provided interfaces support both MEPs. The data exchange model used is FIXM 4.0. The consumers connect to the FPL service directly when request/response is used and directly or through a broker service when publish/subscribe is used.

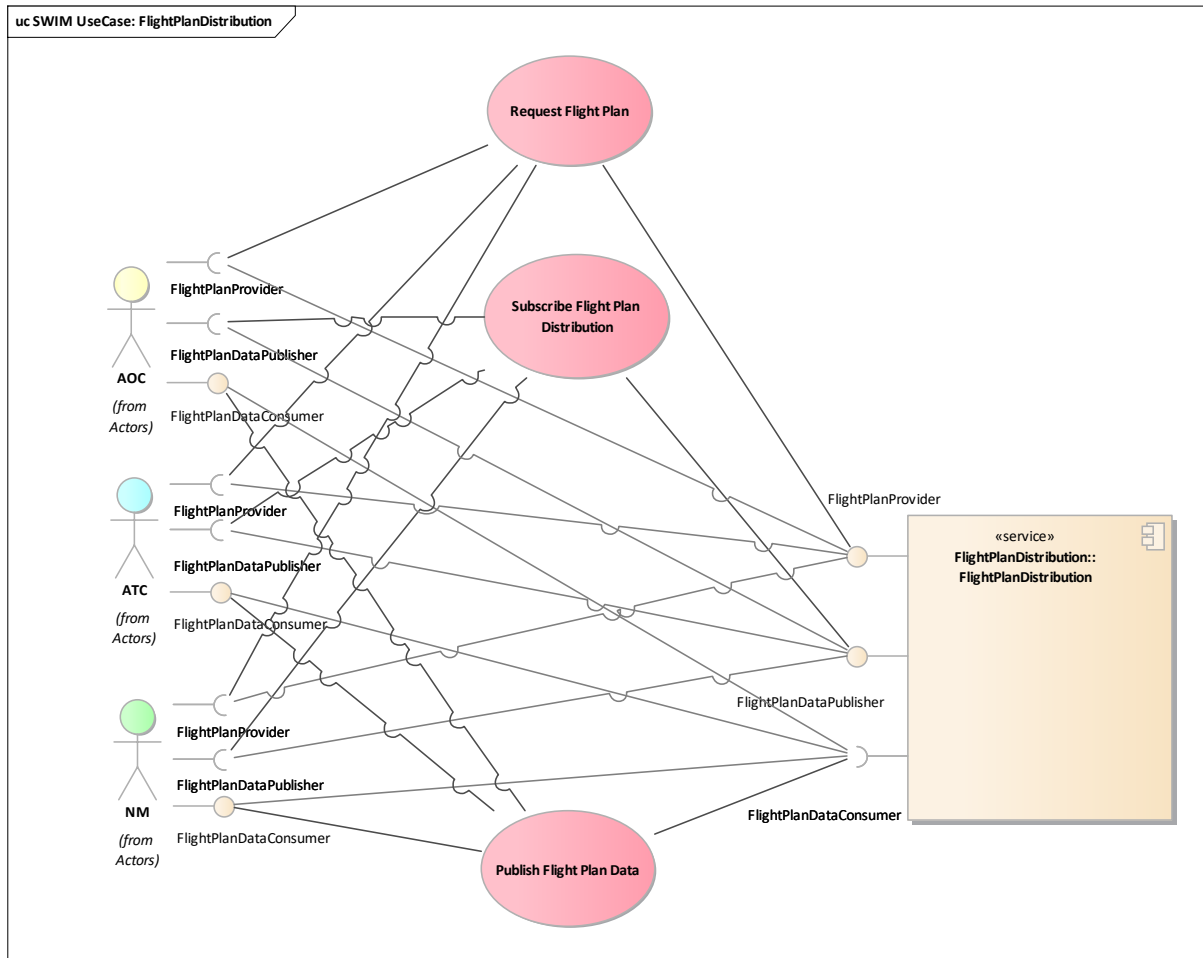

Figure 22: SWIM Use Case: Request/Subscribe/Publish Flight Plan

3.4.2 BEST Use Case: Request/Subscribe/Publish Flight Plan

The SWIM version of the Use Case is supported by the Flight Plan Distribution Service (Annex 11.3) by use of the request/response and publish/subscribe MEPs. The provided interfaces support both MEPs. The data exchange model used is FIXM. The service consumers/subscribers are not connecting and/or subscribing to the information provider directly anymore. Instead, they are connecting and/or subscribing to various semantic containers that maintain/retain the information concerning their area of responsibility that could be provided by a semantic container service. The semantic containers make the decision on whether to (re-) publish information to their subscribers. The consumers are oblivious to the interposed semantic container(s).

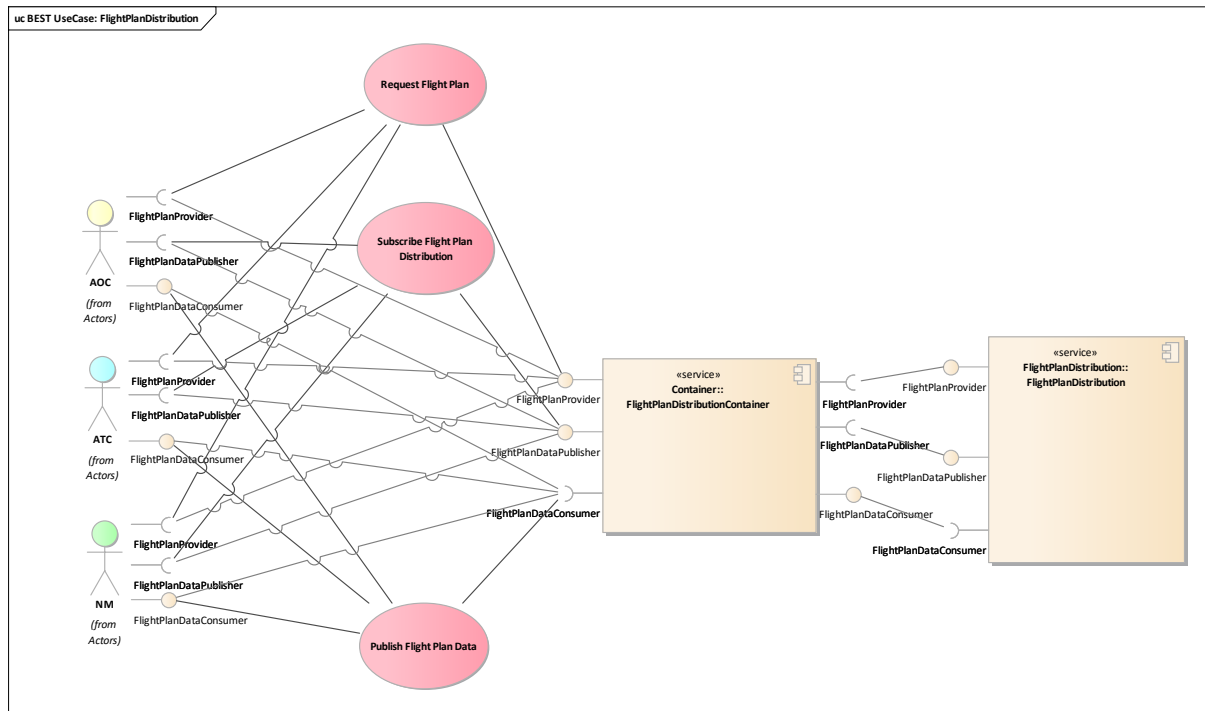

Figure 23: BEST Use Case: Request/Subscribe/Publish Flight Plan

3.4.2.1 Semantic Container – Flight Plan

Similar to the DNOTAM semantic container, there could be semantic containers for AOC, ATC and NM. Figure 24 shows the derivation of an “ATS route Container” with routes relevant for ADEP-ADES for the given date with ATS route annotations specific to actors AOC, ATC and NM and annotations specific to a given aircraft type.

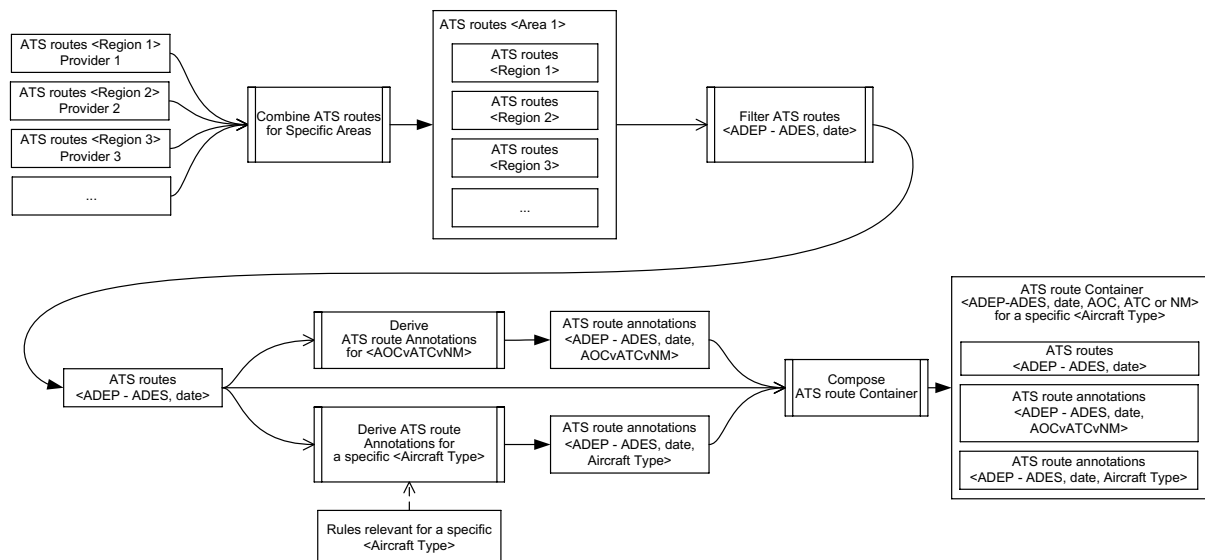

Figure 24: Generic derivation chain of a Semantic Container – Flight Plan

First, activity “Combine ATS routes for specific areas” combines ATS routes for different regions from different providers. The combined routes in homogeneous composite container “ATS routes <Area 1>” are filtered by activity “Filter ATS routes <ADEP-ADES, Date>”.

For the filtered ATS routes in homogeneous composite container “ATS routes <ADEP-ADES, Date>”, activity “Derive ATS route Annotations for <AOC v ATC v NM>” derives annotations that are of interest for actors AOC, ATC or NM. Activity “Derive ATS route Annotations for a specific <Aircraft Type>” uses its static input “Rules relevant for a specific <Aircraft Type>” to derive “ATS route annotations <ADEP-ADES, Date, Aircraft Type>”. Finally, activity “Compose ATS route Container” composes ATS routes and ATS route annotations into a heterogeneous composite container. By using semantic containers benefits in regard to availability (section 3.6.2) can be realized.

3.5 Use Case: Pre-Flight Briefing

This Use Case is linked to the following scenario steps defined in following sections:

- 4.1.1.7 Request ePIB data by AOC from ePIB Service
- 4.1.1.8 Prepare/Customize ePIB by AOC using interactive HMI
- 4.1.1.9 Upload/send ePIB to EFB by AOC
- 4.2.1.8 Request ePIB data by AOC from ePIB Service
- 4.2.1.9 Prepare/Customize ePIB by AOC using interactive HMI
- 4.2.1.10 Upload/send ePIB to EFB by AOC

The Use Case is supported by the Integrated Digital Briefing service by use of the request/response MEP also supported by the provided interface. Interaction with the service is provided by means of specialized HMI that communicates with the service over the provided interface. The data exchange is done in a specialized ePIB format which meshes up AIXM5.1, Digital NOTAM, IWXXM and FIXM formats.

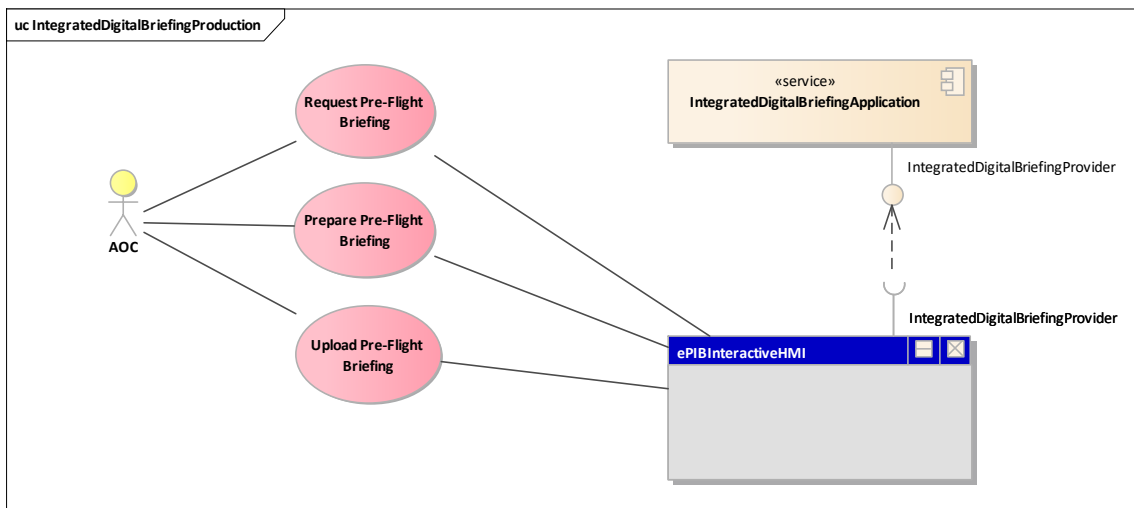

Figure 25: SWIM Use Case: Request/Prepare/Upload Pre-Flight Briefing

In addition it is also possible to subscribe and publish the Pre-Flight Briefing. This Use Case is linked to the following scenario steps defined in following sections:

- 4.1.1.9 Upload/send ePIB to EFB by AOC
- 4.2.1.10 Upload/send ePIB to EFB by AOC

3.5.1 SWIM Use Case: Subscribe/Publish Pre-Flight Briefing

The SWIM version of the Use Case is supported by the Integrated Digital Briefing (Annex 11.5) service by use of the publish/subscribe MEP. The data exchange is done in a specialized ePIB format which mashes up AIXM5.1, Digital NOTAM, IWXXM and FIXM formats. The consumers use the EFB ePIB HMI to connect to the service through a broker and subscribe for ePIB. The service sends any ePIB update to the subscribers over the broker using the publish method. Air/Ground and Ground/Ground communication is made possible.

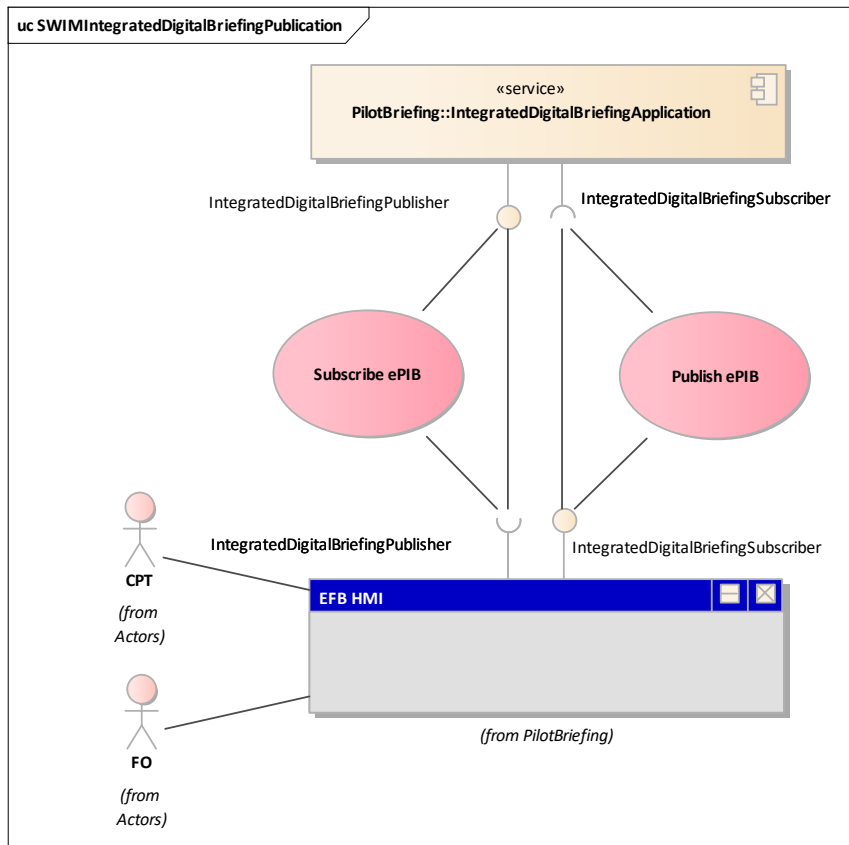

Figure 26: SWIM Use Case: Subscribe/Publish Pre-Flight Briefing

3.5.2 BEST Use Case: Subscribe/Publish Pre-Flight Briefing

The BEST version of the Use Case is also supported by the Integrated Digital Briefing service by use of the publish/subscribe MEP. The data exchange is done in a specialized ePIB format which mashes up AIXM5.1, Digital NOTAM, IWXXM and FIXM formats. The consumers use the EFB ePIB HMI to connect to a specialized BEST semantic container through a broker and subscribe for ePIB. The semantic container that maintains/retains the information concerning its area of responsibility also connects directly or through a broker to the Integrated Digital Briefing service, which sends any ePIB update to its subscribers (using the “publish” method). The semantic container makes the decision on whether to (re-) publish information to its subscribers. Air/Ground and Ground/Ground communication is still made possible.

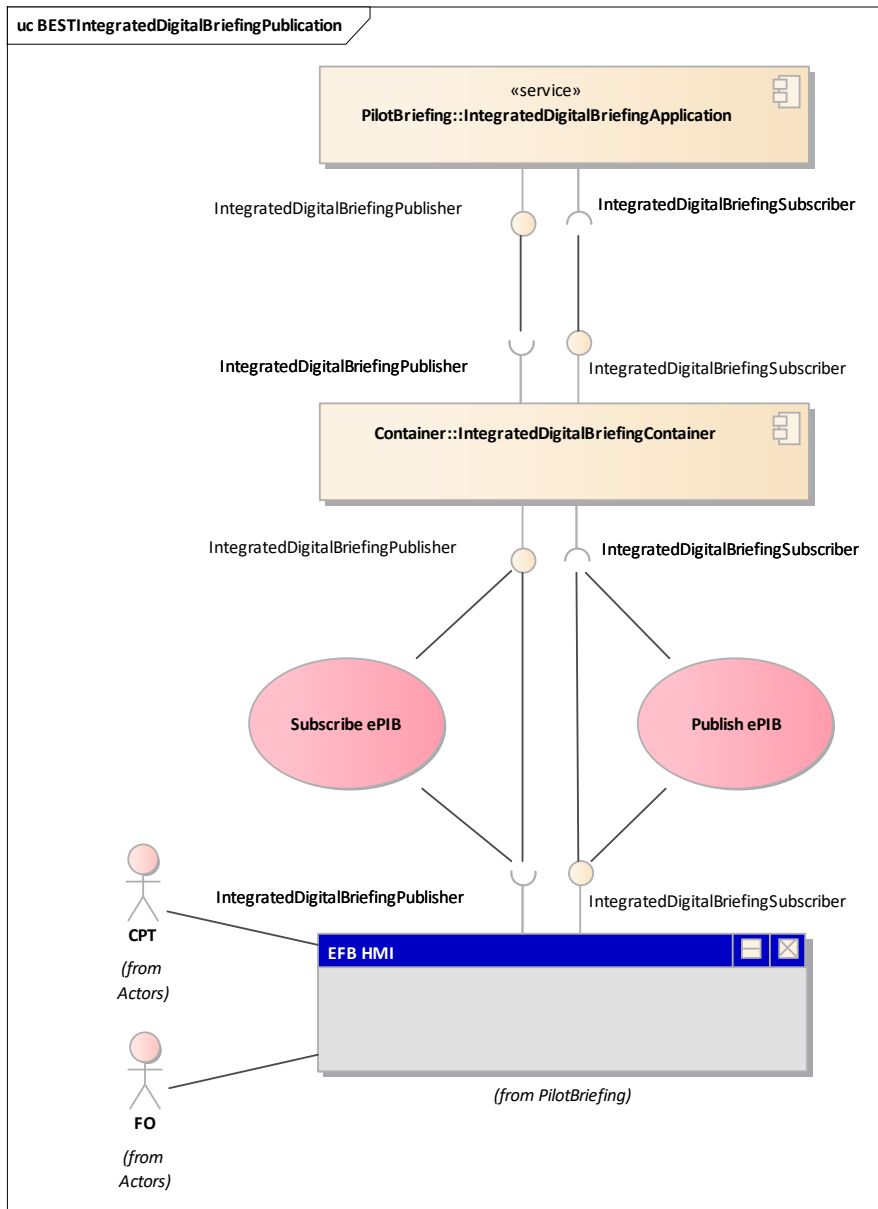

Figure 27: BEST Use Case: Subscribe/Publish Pre-Flight Briefing

3.5.2.1 Semantic Container – Pre-Flight Briefing

Figure 28 shows the derivation of containers for flight briefings. Container “NOTAMs <Europe>” is filtered for NOTAMs relevant to flights from DXB to VIE on 05/04/2017 resulting in container “NOTAMs <DXB-VIE, 05/04/2017>”. The filtered NOTAMs are prioritized with regard to flight EK127 and composed, together with METARs relevant for flight from DXB to VIE on 05/04/2017, into heterogeneous composite container “EFB <Flight: EK127, 05/04/2017>”.

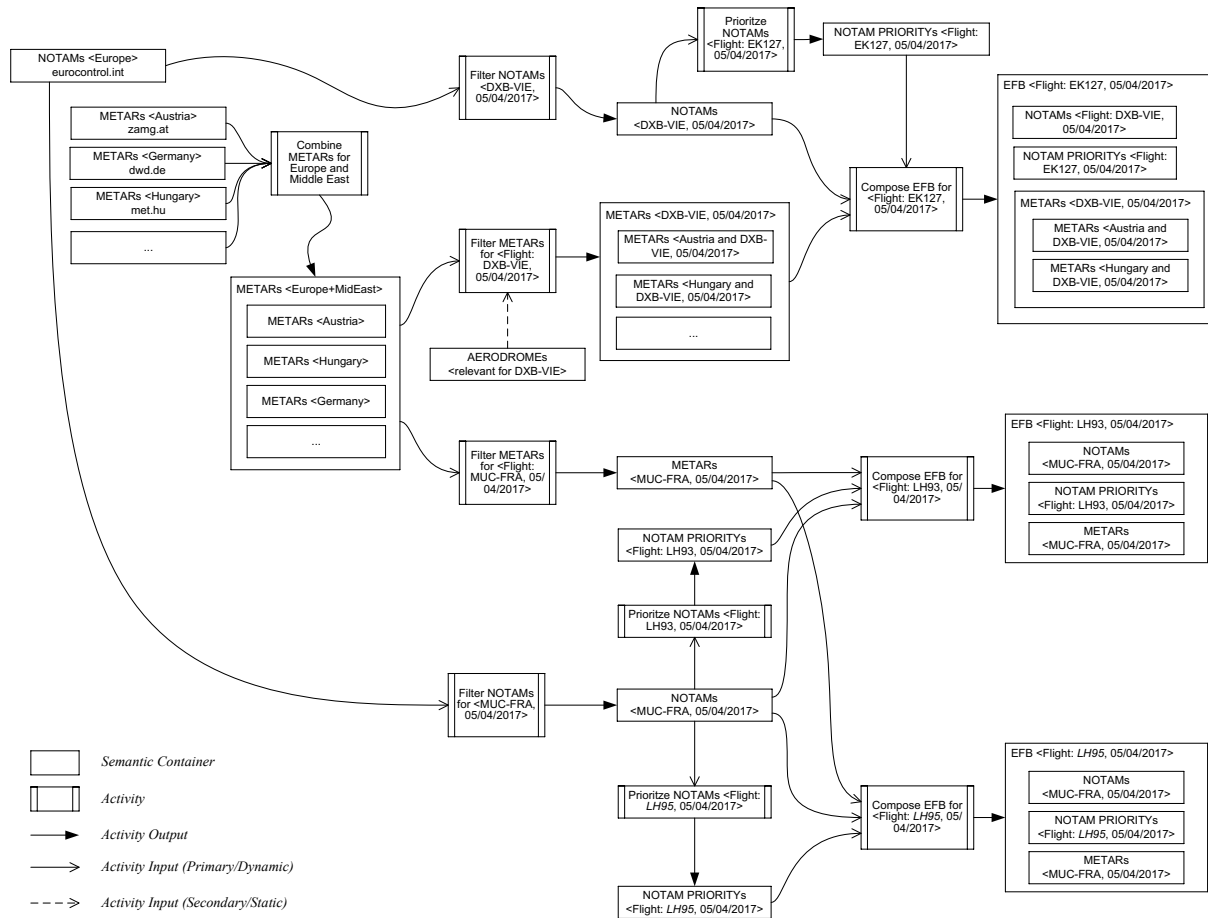

Figure 28: Derivation chain of a Briefing Semantic Container (Schuetz, Neumayer, & Schrefl, D2.1 Techniques for ontology-based data description and discovery in a decentralized SWIM knowledge base, 2018)

METARs are combined from different data sources by activity “Combine METARs for Europe and Middle East” into homogeneous composite container “METARs <Europe+MidEast>” and filtered for flights from DXB to VIE on 05/04/2017. Container “METARs <Europe+MidEast>” is also used as input for activity “Filter METARs for Flight: MUC-FRA, 05/04/2017>” which results in container “METARs <MUC-FRA, 05/04/2017>” containing all METARs relevant for flights from MUC to FRA on 05/04/2017.

Container “NOTAMs <Europe+MidEast>” is also filtered for flights from MUC to FRA on 05/04/2017 resulting in container “NOTAMs <MUC-FRA, 05/04/2017>” which is used as input for two activities. Activity “Prioritize NOTAMs <Flight: LH93, 05/04/2017>” derives priority annotations with regard to flight LH93 on the given date and activity “Prioritize NOTAMs <Flight: LH95, 05/04/2017>” derives priority annotations with regard to flight LH95 on the same day. Finally, NOTAMs and METARs relevant for “<MUC-FRA, 05/04/2017>” together with NOTAM PRIORITYs derived with regard to flight “<LH93, 05/04/2017>” and flight “<LH95, 05/04/2017>” are composed into heterogeneous composite containers “EFB <Flight: LH93, 05/04/2017>” and “EFB <Flight: LH95, 05/04/2017>”.

By using semantic containers benefits in regard to defined quality (section 3.6.1), availability (section 3.6.2) and decreased network load (section 3.6.3) can be realized.

3.6 Benefits

The various use cases presented in the previous sections will lead to benefits described in this section. The main benefits are of

- defined quality of information,
- high availability of information, and
- decreased network load

3.6.1 Defined Quality of Information

The SWIM concept provides mechanisms to support that the right information will be available with the right quality to the right person at the right time. BEST semantic containers support the quality party in the above value proposition of SWIM. Such containers are discovered through concepts (metadata) defined in the AIRM Ontology Modules. The knowledge base emerging from such a set of semantic containers (see D2.1, section 4.2) holds semantically well-defined data items, i.e., ATM data provided according to SWIM standards from the same authoritative source. Each fragment is described by

- freshness (a timestamp of the last update) and
- provenance (a description of entities and activities involved in producing or influencing the data items in the fragment)

These attributes define the quality of a data item and allow data consumers to choose between different sources in case multiple data sets are available.

The knowledge base mentioned above is a distributed and decentralized system, where the providers (or owners) of data in a BEST semantic containers are responsible for the storage location of the content (ATM data). BEST semantic containers provide the metadata to describe its content and SWIM-enabled applications on behalf of the end users' ATM Information Systems can discover the relevant information. This allows providing information about the data like freshness, provenance and quality of the data itself. In addition, the user can select the right SWIM service based on the respective needs.

3.6.2 High Availability of Information

ATM data in general underlies dynamic behaviours and authoritative sources of data frequently issue updates to existing data as well as new data. Keeping hierarchies of semantic containers (replicas and extracts) consistent with their data sources (freshness of data) and providing a high availability and responsiveness is of central importance within the BEST approach to ensure common situational awareness. However, distributing every update immediately to every replica is expensive (e.g., data transfer from ground stations to airplanes en-route) and often also impossible due to network bottlenecks or even failures and because some derived data products, such as an electronic flight bag (EFB), are off-line most of the time.

The different applications and users of SWIM require different kinds of data at different levels of freshness and availability. For example, when an aircraft requests current weather data, consistency

may be sacrificed for achieving high availability, since also slightly outdated weather data can be of use for a pilot, whereas getting no weather data at all could cause severe troubles. On the other hand, if a pilot requests information about whether or not a certain runway is free, it could be disastrous to serve inconsistent, i.e., outdated, information. An information system should therefore alert the pilot that received data is inconsistent or find an alternative source that resolves the inconsistencies. If, for example, weather data is requested but only outdated weather data is currently available, the system could send new weather data to the airplane as soon as it is available, given that the new information is still relevant for the pilot.

BEST semantic containers also increase availability of the overall system by allowing multiple sources for data, i.e., providing redundancy as described in D2.1. Services that rely now on a specific data source inherit the availability of this data provider. By tapping into multiple sources the container switches transparently between available data providers in case of failures. A side benefit of this intermediate position of BEST semantic containers is the possibility to perform network monitoring and establish KPIs about the overall throughput and availability of ATM information.

A scenario highlighting the benefit in terms of high availability is a BEST semantic container that is operated on a flight. The container itself will be instantiated a few days before the actual flight and prefilled with all relevant information. At the departure airport with an established high bandwidth connection the container is transferred to the plane and then only updated with critical information or low bandwidth requiring weather data. With the container readily available at the plain different scenarios like route updates can be performed locally, thus leading to low latency and high availability.

3.6.3 Decreased Network Load

Another significant benefit from the use of BEST semantic containers is a decreased network load due to caching frequently requested information (e.g., weather data) at places with many data consumers. It is quite common that multiple service providers at an airport request the same information from a remote entity but because of the criticality of the data each request is processed individually and generates unnecessary load on the available bandwidth.

Another advantage of caching data in a BEST semantic container together with defined quality of the available data is faster response times. For certain data types (e.g., weather data) with fixed update intervals a container can immediately respond and do not need to check for updates at the original data source.

4 Prototype Use Case Scenarios

The use case scenarios used in this document are based on commercial passenger flights performed by commercial pilots employed by and using aircraft owned or leased by commercial airline companies. All these flights are performed under Instrument Flight Rules (IFR flights) which are composed of clearly defined flight phases. The prototype use cases in chapter 3 show how the semantic container handle the different kind of information and are linked in this chapter to the scenarios.

The steps listed below are adapted to the validation goals of BEST and include only the steps that involve data exchange/transmission relevant to BEST. There are additional intermediate steps such as human actions or notifications of operational events (such as a departure confirmation) that are preformed, but since these do not contribute significantly to the goals of BEST, these were ignored in this document in order to reduce complexity. The following descriptions refer to operational terms explained in APPENDIX B: Operational Scenario.

4.1 Use Case Scenario: Flight YSSY – OMDB

This is one of the two selected use case scenarios, based on the pre-flight briefing scenario, to prove the viability and feasibility of BEST's main concept, and as such will be integrated in the BEST experimental prototype demonstration.

This is a fictive use case – representing a flight from Sydney (YSSY) to Dubai (OMDB) – that has been designed for demonstration purposes by the team that prepared Demo 3 included in the SWIM Global Demo 2016. It was designed to cover multiple aspects of a long-haul high capacity overseas flight confronted with unplanned situations while en-route. The scope was to demonstrate the advanced capabilities of SWIM, which the current ATM systems cannot offer.

4.1.1.1 Publication of METAR, TAF for YSSY, OMDB by MET

The MET service is publishing the METAR and TAF information for the departure airport at predetermined time intervals or as needed if meteorological conditions deviate a lot from previously advertised. This information is needed ahead of commencing the flight. The BEST use case described in section 3.2.2 describes how the information is handled with the semantic container approach.

FLIGHT PHASE: GND

DATA TYPE(S): IWXXM

ACTORS: MET

SWIM MEP: publish

4.1.1.2 Publication of Severe Turbulence SIGMET for OMAE FIR by MET

The MET service is publishing the SIGMET information for the departure airport at predetermined time intervals or as needed if meteorological conditions deviate a lot from previously advertised. This information is needed ahead of commencing the flight.

FLIGHT PHASE: GND

DATA TYPE(S): IWXXM

ACTORS: MET

SWIM MEP: publish

4.1.1.3 Publication of DNOTAM (NAV.UNS and SAA.ACT) by AIM

The NOTAM (office) service is publishing Digital NOTAM, which is advertising any significant operational changes previously not advertised. The BEST use case described in section 3.3.2 describes how the information is handled with the semantic container approach.

FLIGHT PHASE: GND

DATA TYPE(S): AIXM5.1/DNOTAM

ACTORS: AIM

SWIM MEP: publish

4.1.1.4 Publish FPL by AOC for ATC

The Airline Operations Centre files the Flight Plan (FPL) with the Air Traffic Control. The BEST use case described in section 3.4.2 describes how the information is handled with the semantic container approach.

FLIGHT PHASE: GND

DATA TYPE(S): FIXM

ACTORS: AOC

SWIM MEP: publish

4.1.1.5 Publish FPL by ATC for NM

The Air Traffic Control sends the approved Flight Plan (FPL) to the Network Management. The BEST use case described in section 3.4.2 describes how the information is handled with the semantic container approach.

FLIGHT PHASE: GND

DATA TYPE(S): FIXM

ACTORS: ATC

SWIM MEP: publish

4.1.1.6 Publish FPL in SWIM by NM

The Network Management publishes the Flight Plan (FPL) in SWIM for down-stream users/subscribers. The BEST use case described in section 3.4.2 describes how the information is handled with the semantic container approach.

FLIGHT PHASE: GND

DATA TYPE(S): FIXM

ACTORS: NM

SWIM MEP: publish

4.1.1.7 Request ePIB data by AOC from ePIB Service

AOC retrieves ePIB data from AIM ePIB service. The BEST use case described in section 3.5.2 describes how the information is handled with the semantic container approach.

FLIGHT PHASE: GND

DATA TYPE(S): FIXM, AIXM5.1/DNOTAM, IWXXM

ACTORS: AOC

SWIM MEP: request/response

4.1.1.8 Prepare/Customize ePIB by AOC using interactive HMI

AOC prepares/customizes ePIB package for flight crew using interactive ePIB Human-Machine Interface (HMI) application. The BEST use case described in section 3.5.2 describes how the information is handled with the semantic container approach.

FLIGHT PHASE: GND

DATA TYPE(S): not a SWIM supported step

ACTORS: AOC

SWIM MEP: not a SWIM supported step

4.1.1.9 Upload/send ePIB to EFB by AOC

AOC stores the prepared ePIB and uploads the ePIB package to flight crew's EFB. The BEST use case described in section 3.5.2 describes how the information is handled with the semantic container approach.

FLIGHT PHASE: GND

DATA TYPE(S): ePIB, AIXM5.1/DNOTAM, IWXXM

ACTORS: AOC

SWIM MEP: post/publish

4.1.1.10 Publish VA SIGMET for WIIF, WAAF FIRs by EUMETNET Service

EUMETNET publishes Volcanic Ash SIGMET for WIIF, WAAF, before the flight, which is en-route reaches these airspaces.

FLIGHT PHASE: En-RTE

DATA TYPE(S): IWXXM

ACTORS: MET

SWIM MEP: publish

4.1.1.11 Publish DNOTAM (RTE.CLS) by AIM

NOF (AIM) publishes RTE.CLS Digital NOTAM to subscribers.

FLIGHT PHASE: En-RTE

DATA TYPE(S): AIXM5.1/DNOTAM

ACTORS: AIM

SWIM MEP: publish

4.1.1.12 Publish FPL update with re-route by AOC

AOC prepares and publishes modified FPL, which includes a re-routing of the flight on an available alternative route.

FLIGHT PHASE: En-RTE

DATA TYPE(S): FIXM

ACTORS: AOC

SWIM MEP: publish

4.1.1.13 Publication of METAR for OMDB by NCMS MET Service

The Airport MET service (NCMS) publishes the most recent METAR information for OMDB.

FLIGHT PHASE: En-RTE

DATA TYPE(S): IWXXM

ACTORS: MET (NCMS)

SWIM MEP: publish

4.2 Use Case Scenario: Flight OMDB – LOWW

This is one of the two selected use case scenarios, based on the pre-flight briefing scenario, selected to prove the viability and feasibility of BEST’s main concept, and as such will be integrated in the BEST experimental prototype demonstration.

This is also a fictive scenario – representing a flight from Dubai (OMDB) to Vienna (LOWW) – that has been designed for demonstration purposes by the team that prepared Demo 3 included in the SWIM Global Demo 2016. It was designed to cover multiple aspects of a long-haul high capacity overseas flight confronted with unplanned situations while en-route. The scope was to demonstrate the advanced capabilities of SWIM, which the current ATM systems cannot offer.

4.2.1.1 Publication of METAR/TAF for OMDB by NCMS MET Service

The Airport MET service (NCMS) publishes the most recent METAR information for OMDB. The MET service is publishing the METAR and TAF information for the departure airport at predetermined time intervals or as needed if meteorological conditions deviate a lot from previously advertised. This information is needed ahead of commencing the flight. The BEST use case described in section 3.2.2 describes how the information is handled with the semantic container approach.

FLIGHT PHASE: GND
 DATA TYPE(S): IWXXM
 ACTORS: MET (NCMS)
 SWIM MEP: publish

4.2.1.2 Publication of METAR, TAF for LOWW, LOWL by EUMETNET

The Airport MET service publishes the most recent METAR information for LOWW (Vienna) and LOWL (Linz).

FLIGHT PHASE: GND
 DATA TYPE(S): IWXXM
 ACTORS: MET
 SWIM MEP: publish

4.2.1.3 Publication of Severe Icing SIGMET for LOWW TMA/ACC by EUMETNET

The MET service is publishing SIGMET information on Severe Icing for the LOWW airport terminal manoeuvring area (TMA). Severe Icing can affect the lift and control capabilities of an aircraft wing.

FLIGHT PHASE: GND
 DATA TYPE(S): IWXXM
 ACTORS: MET
 SWIM MEP: publish

4.2.1.4 Publication of DNOTAM (RTE.CLS) by GCAA

The NOTAM (office) service is publishing Digital NOTAM, which is advertising any significant operational changes previously not advertised. The BEST use case described in section 3.3.2 describes how the information is handled with the semantic container approach.

FLIGHT PHASE: GND

DATA TYPE(S): AIXM5.1/DNOTAM

ACTORS: AIM

SWIM MEP: publish

4.2.1.5 Publish FPL by AOC for ATC (GCAA)

The Airline Operations Centre files the Flight Plan (FPL) with the Air Traffic Control (General Civil Aviation Authority (GCAA)). The BEST use case described in section 3.4.2 describes how the information is handled with the semantic container approach.

FLIGHT PHASE: GND

DATA TYPE(S): FIXM

ACTORS: AOC

SWIM MEP: publish

4.2.1.6 Publish FPL by ATC (GCAA) for NM

The Air Traffic Control sends the approved Flight Plan (FPL) to the Network Management. The BEST use case described in section 3.4.2 describes how the information is handled with the semantic container approach.

FLIGHT PHASE: GND

DATA TYPE(S): FIXM

ACTORS: ATC

SWIM MEP: publish

4.2.1.7 Publish FPL in SWIM by NM

The Network Management publishes the Flight Plan (FPL) in SWIM for down-stream users/subscribers. The BEST use case described in section 3.4.2 describes how the information is handled with the semantic container approach.

FLIGHT PHASE: GND

DATA TYPE(S): FIXM

ACTORS: NM

SWIM MEP: publish

4.2.1.8 Request ePIB data by AOC from ePIB Service

AOC retrieves ePIB data from AIM ePIB service. The BEST use case described in section 3.5.2 describes how the information is handled with the semantic container approach.

FLIGHT PHASE: GND

DATA TYPE(S): FIXM, AIXM5.1/DNOTAM, IWXXM

ACTORS: AOC

SWIM MEP: request/response

4.2.1.9 Prepare/Customize ePIB by AOC using interactive HMI

AOC prepares/customizes ePIB package for flight crew using interactive ePIB HMI application. The BEST use case described in section 3.5.2 describes how the information is handled with the semantic container approach.

FLIGHT PHASE: GND

DATA TYPE(S): not a SWIM supported step

ACTORS: AOC

SWIM MEP: not a SWIM supported step

4.2.1.10 Upload/send ePIB to EFB by AOC

AOC stores the prepared ePIB and uploads the ePIB package to flight crew's EFB. The BEST use case described in section 3.5.2 describes how the information is handled with the semantic container approach.

FLIGHT PHASE: GND

DATA TYPE(S): ePIB, AIXM5.1/DNOTAM, IWXXM

ACTORS: AOC

SWIM MEP: post/publish

4.2.1.11 Publication of Turbulence SIGMET for LRBB by EUMETNET

EUMETNET publishes Turbulence SIGMET for LRBB, before the flight, which is en-route reaches the Romanian national airspace.

FLIGHT PHASE: En-RTE

DATA TYPE(S): IWXXM

ACTORS: MET

SWIM MEP: publish

4.2.1.12 Publication of Thunderstorm SIGMET for LHCC by EUMETNET

EUMETNET publishes Thunderstorm SIGMET for LHCC, before the flight, which is en-route reaches the Hungarian national airspace.

FLIGHT PHASE: En-RTE
DATA TYPE(S): IWXXM
ACTORS: MET
SWIM MEP: publish

4.2.1.13 Publish FPL update with re-route by AOC

AOC prepares and publishes modified FPL, which includes a re-routing of the flight on an available alternative route.

FLIGHT PHASE: En-RTE
DATA TYPE(S): FIXM
ACTORS: AOC
SWIM MEP: publish

4.2.1.14 Publication of DNOTAM (RWY.CLS) by ACG

The NOTAM (office) service is publishing Digital NOTAM, which is advertising any significant operational changes previously not advertised

FLIGHT PHASE: GND
DATA TYPE(S): AIXM5.1/DNOTAM
ACTORS: AIM
SWIM MEP: publish

5 Conclusion and Future Work

5.1 Conclusion

This document briefly described the motivation of this deliverable, the current operational information exchange, the SWIM enabled one, and compared it with SWIM combined with BEST in place. Furthermore the BEST semantic container approach, including the semantic container derivation chains, has been described. The document gave an overview about the use case actors and listed various prototype use cases envisioned by the BEST approach. It gave an insight into how versatile the BEST approach can be used. In specific chapter 3 showed the difference between the SWIM enabled operational method, and the SWIM+BEST enabled operational method. Several use cases focused on how aeronautical, meteorological, or flight plan information is exchange with the BEST approach. At the end of this chapter the benefits like defined quality of information, high availability of information, and decreased network load have been introduced. For the experimental prototyping two use cases scenarios have been introduced.

The envisioned BEST semantic container approach will lead to the development of new business processes, identification, customization and reuse of ISRM services and will show the actual benefits of SWIM, by using aggregated information to gain new knowledge.

Clearly more research is needed on the implications of semantic container in SWIM environment, especially in interaction with a SWIM service (& container) registry to provide future SWIM applications information in an even better way.

5.2 Future Use Cases

This section briefly describes further possible use cases which can be envisioned with the BEST approach in place. It describes the diversity of possible use cases the semantic container approach can support:

Air Traffic Flow and Capacity Management

Air Traffic Flow and Capacity Management (ATFCM) relies on data analysis in order to manage and plan air traffic flow. As a consequence, ATM information must be organized in data structures suitable for data analysis. While statistical data can be organized in traditional data warehouses, individual messages such as NOTAMs and METARs as well as flight plans contain valuable information about air traffic flow beyond statistics, which ATFCM could tap into for data analysis. In this regard, the challenge lies in the structured storage of the various information items into containers along semantic dimensions that allow for the flexible combination of information of different scopes. ATFCM analysts may then employ appropriate query facilities and analytics mechanisms to gain insights from the information and present the information to ATM stakeholders.

The analysis of various kinds of ATM information, e.g., NOTAMs, METARs, and flight plans may improve prediction and planning of air traffic flow in the strategic and (pre-)tactical phases of ATFCM, or improve post-operational conclusions. Consideration may hence be given to structured data lake approaches that organize the original ATM information in a way that renders the vast amounts of data manageable and usable in the analytical process. Research shall, at a minimum, address the storage of various kinds of ATM information in a (hierarchical) structure that allows for

the flexible combination of ATM information of different scopes and ad hoc data analysis. The conceptual and logical as well as physical aspects of such data structures may be investigated, along with the corresponding query facilities and analytics mechanisms. Research may also investigate the potential of semantic technologies in general and ontologies in particular towards organizing ATM information for data analysis, possibly in the form of semantic containers. The information and domain knowledge relevant for ATFCM, and must be organized appropriately.

Improved organization of ATM information in semantic containers suitable for data analysis will facilitate the integration of the information into ATFCM. Data analyses in all phases of ATFCM, from strategic and (pre-)tactical phases to the post-operational, may benefit from better organization of all kinds of ATM information for analytical purposes. This could include a flow service with distributed airline recovery, distributed airline schedule recovery automation for utilizing combinations of ground delay, flight cancellation, and pre-departure re-routing in response to convective weather disruptions. It also could be foreseen that there are different semantic containers for different flight phases (see APPENDIX A: Anatomy of a Flight).

Flight-Plan Service

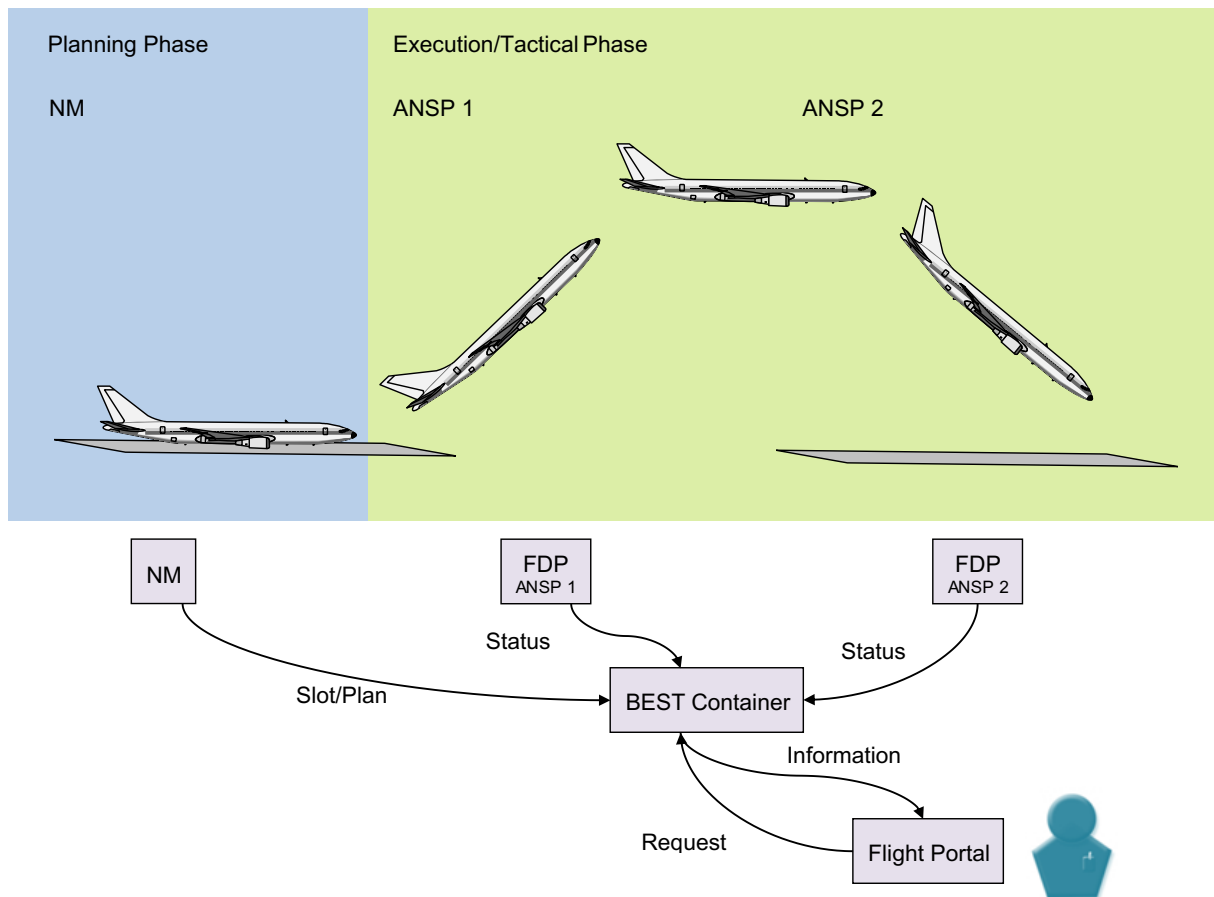

Figure 29: Possible BEST-enabled Flight Service

From the beginning of BEST it was decided not to focus on flight information but for the future this should be a topic as well. A BEST-enabled flight plan service intends to provide information about flights to prospecting partners via pre-calculated containers. To be able to do so, information from two other partners Network Manager (NM) and Flight Data Processing (FDP) is required. The fact, that one partner (NM) is an organization and the other (FDP) is a system within another organisation, an Air Navigation Service Provider (ANSP), is irrelevant for the example. The Flight Plan Service collects all information and refines it. The flight-plan containers will collect all available information for the main ATS routes. Upon request, the service provides the information in restructured form to a portal where users are able to query information about flights of their interest. To allow for the highest degree of transparency, all communication is established by using SWIM.

Sector-less ATC

Sector-less ATC is a future operational scenario for air traffic management in upper airspace. It envisions en-route air traffic control without conventional sectors (Korn, Edinger, Tittel, Pütz, & Mohrhard, 2010), (Reinhardt, Poppe, & Herr, 2015). One controller will be assigned several aircraft regardless of their location and will guide these aircraft during their entire flight in upper airspace. This new concept promises a significant increase in capacity and controller efficiency. Furthermore, this aircraft-centred approach provides more flexibility, fewer handovers and enables user preferred routes. The current practice of partitioning airspace into sectors is reaching its limit. Already today there are examples of sectors which cannot be made any smaller, such as the upper airspace sector above Würzburg according to the SESAR Project Description of Project 10.1b (SESAR 2020 Pj10.1b, 2017). Transit times will decrease for such sectors, while the need for controller coordination will increase considerably. Flight-centred ATC addresses these problems by relinquishing the idea of sectors. Instead, it looks at airspace as one piece without conventional sectors.

So far, this concept has been validated in SESAR 1 assigning up to six aircraft to one controller, regardless of the aircraft's geographic position. The controllers are responsible for these flights from the entry into airspace to the exit. A controller may only give instructions to the pilots of assigned aircraft. There are no more handovers between controllers as one controller guides the flight all the way through the airspace. There are no handover points, which decrease the need for controller coordination and enables pilots to follow user preferred routes. The controller has one radar display for each aircraft under control, on which he can track the path of his aircraft and the surrounding traffic. During a predicted conflict, the controller is supported by tools telling him about the foreseen conflict. Various functionalities support the conflict analysis. A set of unambiguous priority rules help to determine responsibility in case of a conflict and avoid the need for coordination with other controllers. Automatic suggestions for avoidance manoeuvres and probing capabilities complete the support tools and help the controller to find the most efficient conflict solution and maintain safety.

The BEST container approach supports most of the involved SWIM-actors in this scenario by packaging the need information in pre-defined containers to raise the efficiency. An even workload distribution and greatly reduced need for coordination allows controllers to work more efficiently and concentrate on their main task: conflict resolution. Additionally, controllers can work more flexibly and are no longer restricted by sector-licensing. This opens up new possibilities for contingency solutions. Since there are no handover points between sectors anymore, pilots can follow user preferred routes and have the advantage of only one contact person during their entire

flight. This operational scenario allows easy integration of new vehicle types with different flight performances, such as Remotely Piloted Aircraft Systems (RPAS).

Other possible Use Cases

Since the semantic container approach is adoptable many other use cases are possible:

Improved surface movement planning through increased automation and integration of multiple data sources is another possible use case. Surface optimization algorithms already show promising results in taxi delays, stop, and fuel/emissions in heavy traffic situations. Average delay of departure aircraft in the movement area or the average number of stops can be reduced during heavy traffic situations when compared between advisory and non-advisory conditions. The approach of BEST will also bring improvements on this side and will save, fuel consumption and engine emissions generated by taxiing aircraft in the movement area through more efficient information exchange via SWIM.

Resectorization, the dynamic splitting and combining of sectors based on traffic load predictions is another future operational scenario, which can benefit from the BEST approach since the semantic container will allow quicker calculation of dynamic sectors.

Arrival management service is another use cases which could benefit by BEST. The service enables continuous descent arrivals through centralized coordination via datalink and 4D trajectories. The BEST approach can be utilized since specific airport related semantic containers can be used for this operation to improve the arrival management service.

Collaborative multi-runway determines preferred runway assignments and arrival sequences while observing constraints such as minimum separations at fixes and runways. Improve airline schedule effectiveness by considering relative flight values and passenger connect data can benefit from the semantic container approach.

6 References

- Brataas, G., Neumayr, B., Schuetz, C., & Vennesland, A. (2018). *D5.1 Scalability Guidelines for Semantic SWIM-based Applications*.
- DFS Deutsche Flugsicherung. (2012). Langen.
- ECCAIRS. (n.d.). *1.3.0.12 Data Definition Standard*. ICAO.
- Eurocontrol. (2016). *Aeronautical Information Exchange Model (AIXM)*. (Eurocontrol) Retrieved from <http://www.aixm.aero/>
- Eurocontrol. (2016). *Flight Information Exchange Model (FIXM)*. Retrieved from <http://www.fixm.aero>
- Eurocontrol. (2017). *ATFCM Operations Manual - Network Operations Handbook*. Brussels: Network Manager.
- Eurocontrol. (n.d.). *Weather Information Exchange Model (WXXM)*. Retrieved 05 10, 2017, from <http://www.wxxm.aero>
- Gringinger, E., & Fabianek, C. (2018). *D3.2 Prototype SWIM-enabled Applications*.
- Häggsström, N., Michel Denys, M., van Hamme, W., König, H., Winkler, L., Marrazzo, G., & Jiménez, A. A. (2016). *ISRM Service Portfolio*. SESAR Joint Undertaking.
- Korn, B., Edinger, C., Tittel, S., Pütz, T., & Mohrhard, B. (2010). *SECTORLESS ATM – Analysis and Simulation Results*. 27. ICAS (International Council of the Aeronautical Sciences) Conference.
- Kovacic, I., Steiner, D., Schuetz, C., Neumayr, B., Burgstaller, F., Schrefl, M., & Wilson, S. (2017). *Ontology-based Data Description and Discovery in a SWIM Environment*. *Integrated Communications Navigation and Surveillance Conference (ICNS)*. Washington D.C.
- Neumayr, B., Gringinger, E., Schütz, C., Schrefl, M., Wilson, S., & Audun, V. (2017). *Semantic data containers for realizing the full potential of system wide information management*. *2017 IEEE/AIAA 36th Digital Avionics Systems Conference (DASC)*. St. Petersburg, FL.
- Reinhardt, K., Poppe, M., & Herr, M. (2015). *Increasing Capacity or Productivity with Controller Assistance Tools in High Complexity Airspace*. Prague: 34th Digital Avionics Systems Conference (DASC).
- Schuetz, C., Neumayer, B., & Schrefl, M. (2018). *D2.1 Techniques for ontology-based data description and discovery in a decentralized SWIM knowledge base*.
- Schuetz, C., Neumayr, B., & Schrefl, M. (2018). *D2.2 Ontology-based techniques for data distribution and consistency management in a SWIM environment*.
- SESAR 2020 Pj10.1b. (2017). *Project Description 1.0*. Brussels: SJU.
- Vennesland, A., Gringinger, E., & Mirhossein, R. (2018). *D4.4 Tutorial for Software Developers*.

Vennesland, A., Neumayr, B., Schuetz, C., & Savulov, A. (2017). *D1.1 Experimental ontology modules formalising concept definition of ATM data.*

7 Table of Figures

Figure 1: Air Traffic Services routes for Germany (DFS Deutsche Flugsicherung, 2012).....	9
Figure 2: Flight routes of inner Germany flights (DFS Deutsche Flugsicherung, 2012).....	11
Figure 3: Overview of functions of generic Air Traffic Control systems	12
Figure 4: ATM Transition to SWIM	14
Figure 5: How Semantic Containers fit in to SWIM	16
Figure 6: Semantic Container derivation chains with concrete examples.	18
Figure 7: Use Case Actors	19
Figure 8: SWIM Services applied for the Use Cases	20
Figure 9: SWIM Use Case: Retrieve Aeronautical Information Feature	21
Figure 10: BEST Use Case: Retrieve Aeronautical Information Feature	22
Figure 11: Generic derivation chain of an Aeronautical Information Semantic Container	23
Figure 12: SWIM Use Case: Subscribe/Publish MET Information.....	25
Figure 13: BEST Use Case: Subscribe/Publish MET Information	26
Figure 14: Generic derivation chain of a MET Aerodrome Semantic Container	27
Figure 15: Generic derivation chain of a MET Airpace Semantic Container	28
Figure 16: Generic derivation chain of a MET Route Semantic Container	29
Figure 17: SWIM Use Case: Request/Subscribe/Publish Digital NOTAM	30
Figure 18: BEST Use Case: Request/Subscribe/Publish Digital NOTAM	31
Figure 19: Generic derivation chain of a DNOTAM Aerodrome Semantic Container	31
Figure 20: Generic derivation chain of a Semantic Container - DNOTAM Airspace.....	32
Figure 21: Generic derivation chain of a Semantic Container - DNOTAM Route.....	33
Figure 22: SWIM Use Case: Request/Subscribe/Publish Flight Plan.....	34
Figure 23: BEST Use Case: Request/Subscribe/Publish Flight Plan	35
Figure 24: Generic derivation chain of a Semantic Container – Flight Plan	35
Figure 25: SWIM Use Case: Request/Prepare/Upload Pre-Flight Briefing	36
Figure 26: SWIM Use Case: Subscribe/Publish Pre-Flight Briefing	37
Figure 27: BEST Use Case: Subscribe/Publish Pre-Flight Briefing	38
Figure 28: Derivation chain of a Briefing Semantic Container (Schuetz, Neumayer, & Schrefl, D2.1 Techniques for ontology-based data description and discovery in a decentralized SWIM knowledge base, 2018)	39
Figure 29: Possible BEST-enabled Flight Service.....	51
Figure 30: Flight Phases	61
Figure 31: Rerouting Scenario	63
Figure 32: Aeronautical Information Feature Service (AIFS)	64
Figure 33: Aeronautical Information Notification Service (AINS).....	64
Figure 34: Flight Plan Distribution Service.....	65
Figure 35: Meteorology Services: METAR, TAF, MET Hazard En-route Observation (SIGMET)	66
Figure 36: Integrated Digital Briefing Service	67

8 Abbreviations

Acronym/Abbreviation	Explanation
ACC	Area Control Centre
ADEP	Departure Airport Operator
ADES	Destination Airport Operator
AIM	Aeronautical Information Management (Data Provider)
AIXM	Aeronautical Information Exchange Model
AIRM	ATM Information Reference Model
ALT	Alternate Airport Operator
ANSP	Air Navigation Service Provider
AOC	Airline Operations Centre
AOWIR	Aircraft Operator What-If-Reroute
APP	Approach
ARR	Arrival
ATC	Air Traffic Control Operator
ATFCM	Air Traffic Flow and Capacity Management
ATS	Air Traffic Services
ATM	Air Traffic Management
BEST	Achieving the BEnefits of SWIM by making smart use of Semantic Technologies
CPT	Captain (Operating Pilot)
CRCO	Central Route Charges Office
CTO	Controlled Time of Arrival
CTOT	Calculated Take-Off Time
CTR	Centre
DEP	Departure
DFS	Deutsche Flugsicherung
DNOTAM	Digital NOtice To AirMen
EAD	European AIS Database
EN-RTE	En-Route
EOBT	Estimated Off Block Time
ePIB	enhanced-PIB
ETA	Estimated Time of Arrival

ETFMS	Enhanced Tactical Flow Management System
FDP	Flight Data Processing
FEI	Flight Efficiency Initiative
FIR	Flight Information Regions
FIXM	Flight Information Exchange Model
FMP	Flow Management Positions
FO	First Officer (Operating Co-Pilot)
FPL	Flight Plan
GCAA	General Civil Aviation Authority
GND	Ground
HMI	Human-Machine Interface
IATA	International Air Transport Association
ICAO	International Civil Aviation Organization
IFR	Instrument Flight Rules
ISRM	Information Service Reference Model
IWXXM	ICAO Meteorological Information Exchange Model
LOWL	Linz Airport (IATA: LNZ, ICAO: LOWL)
LOWW	Vienna International Airport (IATA: VIE, ICAO: LOWW)
MEP	Message Exchange Pattern
MET	Meteorological Information (Data Provider)
METAR	Meteorological Terminal Air Report
NCMS	National Center of Meteorology & Seismology
NID	Network Impact Display
NM	Network Management Operator
NMOC	Network Manager Operations Centre
NOAA	National Oceanic and Atmospheric Administration
NOTAM	NOTice To AirMen
OMDB	Dubai International Airport (IATA: DXB, ICAO: OMDB)
PIB	Pre-flight Information Bulletin
RRP	Rerouting Proposal
RFP	Replacement Flight Plan Procedure
SIGMET	Significant Meteorological Information
SWIM	System Wide Information Management
TAF	Terminal Area Forecast)

TMA	Traffic Management Advisor
TWR	Tower
WXXM	Weather Information Exchange Model
YSSY	Sydney Kingsford Smith Airport (IATA: SYD, ICAO: YSSY)

9 APPENDIX A: Anatomy of a Flight

The following is a succinct description of flight phases and transition events encountered in this document and is baseline information for chapter 4.

Based on the type of manoeuvres performed by the aircraft the following phases are identified:

- Stand** – the aircraft is immobilized on a parking position
- Taxi** – the aircraft is moving on designated ground surfaces without becoming airborne towards the take-off position
- Take-off** – the aircraft is accelerating from a start position down the runway and becomes airborne once the take-off speed is reached
- Climb** – the aircraft is increasing its flight altitude until it reaches its planned cruise altitude
- Cruise** – the aircraft is flying at cruise-speed and –altitude towards its destination
- Descent** – the aircraft is decreasing its flight altitude until it reaches the approach altitude
- Approach and Landing** – the aircraft follows a critical instrument governed descent path towards the threshold of the runway for landing, makes contact with and rolls down the runway while slowing down to a safe taxiing speed or a full stop (e.g. for backtracking)
- Taxi** – the aircraft is exiting the runway and is moving on designated ground surfaces without becoming airborne towards the final parking position
- Stand** - the aircraft is immobilized on a final parking position

The transitions between these phases are marked by the following events:

- Off-block Time** – the time the nose-gear blocks are removed and the aircraft can move freely officially specified as Estimated Off-Block Time or EOBT in the flight plan
- Take-off** – the time the gear leaves the ground and the aircraft becomes airborne
- Top of Climb** – the time when the cruise altitude is reached
- Top of Descent** – the time when the cruise phase ends and descent to destination begins
- Touchdown / ETA** – the time the gear contacts the ground, officially specified as Estimated Arrival Time or ETA in the flight plan
- On-Block Time** – the time the nose-gear blocks are placed and the aircraft is immobilized, which concludes the flight

Figure 30 depicts these phases and transition events in a graphical form.

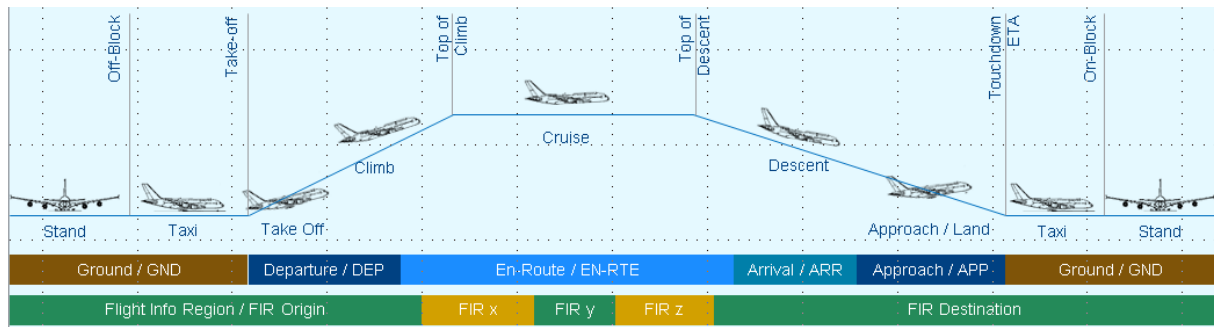

Figure 30: Flight Phases

From an Air Traffic Control (ATC) perspective, there are other phases, some of which can overlap multiple manoeuvres ():

Ground/GND – covers parking, off-block time and ground movement up to take-off

Departure/DEP – covers the first part of the climb

En-Route/EN-RTE – covers the last part of the climb, cruise and first part of the descent

Arrival / ARR – covers the final part of the flight (usually during descent) all the way to the start of approach

Approach / APP – covers the critical instrument governed descent towards the threshold of the landing runway, the touchdown and subsequent braking and rolling all the way to the runway exit

Ground/GND – covers the ground movement from the runway exit to the final parking position

There are two major types of Air Traffic Control functions:

Tower (or TWR), which are airport based and usually cover Ground, Departure, Arrival and Approach, where the responsibility is with one or more controllers depending on the airport/aerodrome size and/or complexity (e.g. large size/capacity ones have multiple approach controllers for each end of a runway in use)

Centre (or CTR), which cover the En-Route phase and are separated/distributed into/over national Flight Information Regions (FIRs) and Airspaces.

For international flights or those performed in some larger and/or very populated countries, the Climb, En-Route and Descent phases of the flight may/will cross at least one Flight Information Region (FIR) or Airspace boundaries (). A FIR is controlled by a country, while a country has one or more FIRs. Individual Airspaces are fully contained subsets of their associated FIR.

10 APPENDIX B: Operational Scenario

10.1 Rerouting of Flights

The operational scenario describes an air traffic situation for which documentation of the events and incidents that occurred exists and are air traffic management situations developed with the help of air traffic actors (ATC, ATM, Airspace Users) for demonstration and validation of concepts purposes. The Use Case Scenario: Flight OMDB – LOWW described in this document will be used for the prototype scenario of BEST. For a better understanding, the description of the first operational scenario includes a comparison of the current operational method, the future SWIM enabled scenario, and the scenario enhance by using the BEST approach. The first view describes how the tactical operations are performed today, the second outlines how these will be performed within the SWIM ecosystem, and is the third shows how this could be done with the BEST approach added in SWIM. With SWIM in place, the operational process will not change instantly, but it can be used to pave the way for new operational concepts. With the BEST scenarios outlined in this document, existing operational processes will change. The BEST semantic container approach improves the availability as well as safe and secure delivery of information. During situations when critical data sources/services become unavailable BEST can identify alternative BEST containers to compensate for unavailability. BEST is also able to offer service users information on the quality of the available information and how far it deviates from the expected quality.

The listed operational scenarios are not intended to be exhaustive nor a complete list. However, they address various fields of applicability and cover several distinct operations to demonstrate the diverse ways the BEST approach can be utilized. Since the operational scenarios for BEST are manifold, the following section provides an overview covering usual scenarios encountered during day-to-day operations. This is a very good example where the full potential of BEST comes to light. This is especially the case when various data streams are aggregated together. Rerouting of flights can have various reasons. One situation that can lead to a rerouting is due to drastic fluctuations in the available capacity of airspaces. In this particular case it may be necessary to use a different flight path, which is called rerouting. Airspace can be closed because of poor weather conditions. Such extreme weather conditions can reduce the capacity of a specific airspace or airport, in worst cases the capacity can drop to zero. As a result, flight controllers have to reroute the aircraft via alternate routes, in order to accommodate the changes in capacity.

Figure 31 uses two different flights to illustrate this operational scenario. On the left, the routes are shown as planned initially. On the right, due to extreme weather conditions, a closed airspace is created, and both flights need to be rerouted. As soon as an aircraft is informed about the imminent rerouting, the new flight-path can be selected without adding more delay than necessary. In , Flight F1 is already very near to the newly closed airspace and therefore has to take a sharper detour that adds more to its remaining trajectory as flight F2, which being further away, can select a trajectory that extends the original remaining one by a smaller percentage and doesn't require sharp manoeuvring. This scenario of simulating an airspace closure was selected in order to compare today's procedures and information exchanges with the improved ones expected to be put in place when ATM will use the SWIM enabled infrastructure, and subsequently perform the comparison with the BEST approach added in place.

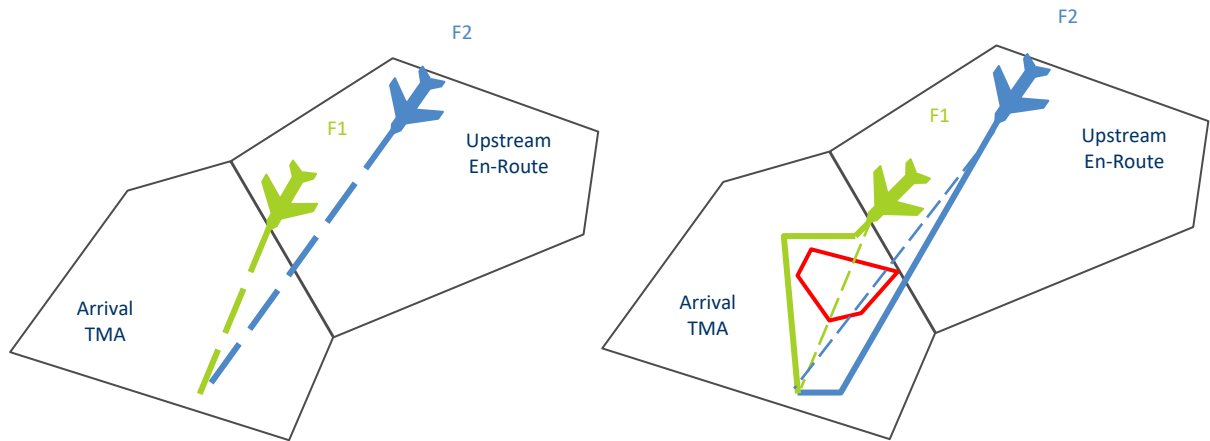

Figure 31: Rerouting Scenario

11 APPENDIX C: SWIM Services

11.1 Provider Service: Aeronautical Information Feature

The ISRM Aeronautical Information Feature Service (AIFS) is a Web Feature Service (WFS) specialization that supports the provision of Aeronautical Information (AIM data) using the AIXM5.1 data exchange model and its extension, Digital NOTAM. The service can provide both types of AIM data, Static Features (Airport, Runway, NAVAID, Airspace, etc.) and Dynamic Features (Digital NOTAM events). The service supports the request/response SWIM MEP.

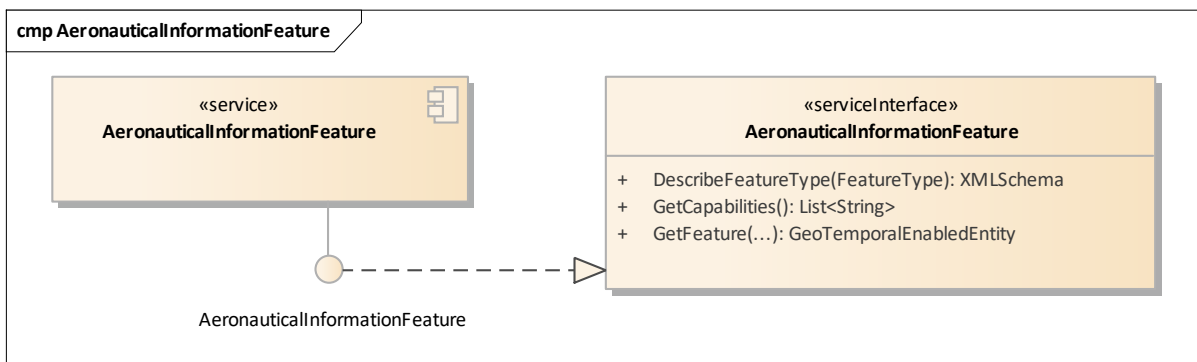

Figure 32: Aeronautical Information Feature Service (AIFS)

11.2 Provider Service: Aeronautical Information Notification

The ISRM Aeronautical Information Notification Service (AINS) supports the provision of Aeronautical Information Notifications using the AIXM5.1 data exchange model and specifically its extension, Digital NOTAM. The service is intended to support Digital NOTAM dissemination. The service supports the request/response and publish/subscribe SWIM MEPs.

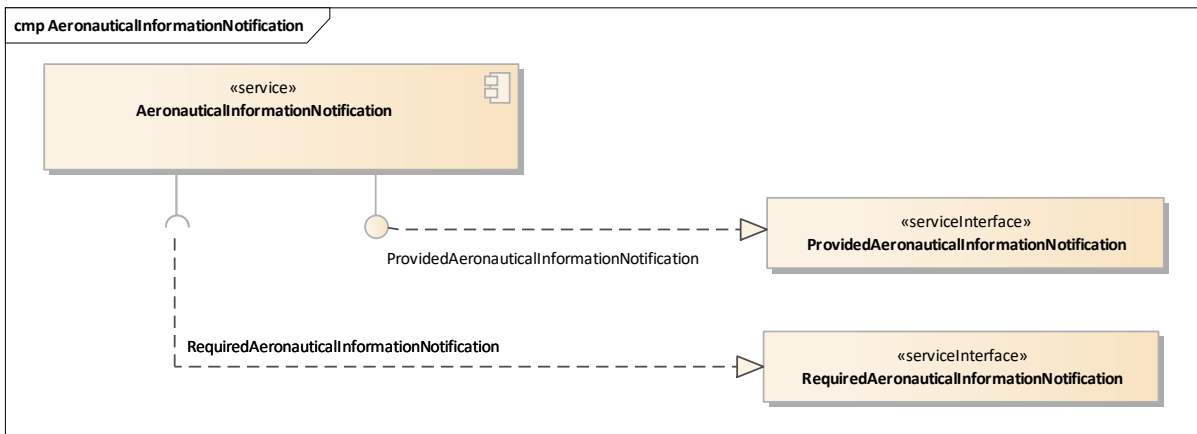

Figure 33: Aeronautical Information Notification Service (AINS)

11.3 Provider Service: Flight Plan Distribution

The ISRM Flight Plan Distribution service is designed for publication and/or provision upon request of Flight Plans (FPL). The FPL data is exchanged in FXXM format. The service supports two SWIM MEPs:

- Request/response through the FlightPlanProvider interface
- Publish/subscribe through the FlightPlanDataPublisher interface for registering subscribers
- FlightPlanDataConsumer required interface to publish to subscribers

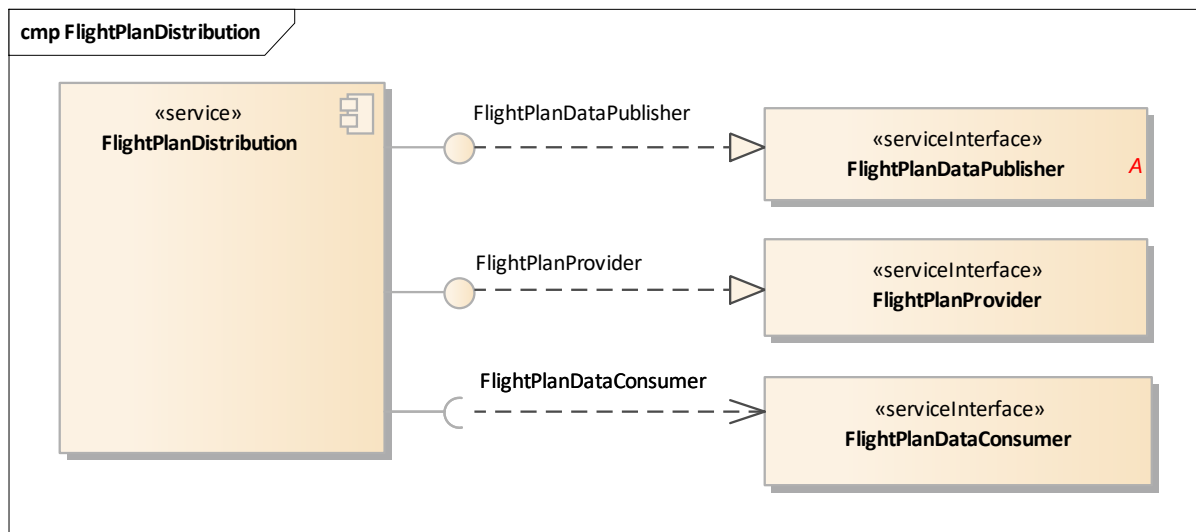

Figure 34: Flight Plan Distribution Service

11.4 Provider Services: Meteorology

The Meteorology services listed here provide the following types of MET information:

- METAR, current meteorological condition at a given airport
- TAF, meteorological forecast for a given airport
- SIGMET, observed significant meteorological conditions for the en-route phase

All services are exchanging data in IWXXM format. The supported SWIM MEP is publish/subscribe. All services implement and expose a provider service interface for allowing subscriptions and require a consumer service interface for publication to subscribers.

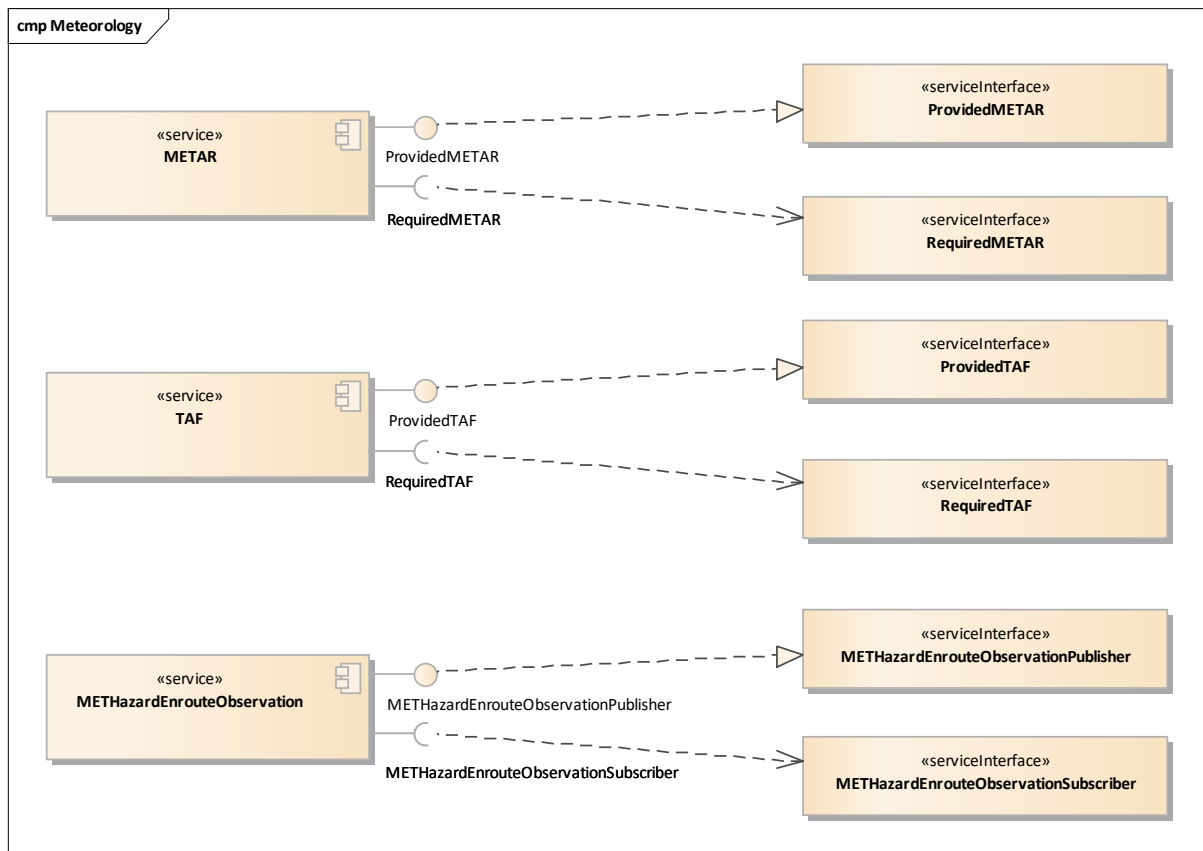

Figure 35: Meteorology Services: METAR, TAF, MET Hazard En-route Observation (SIGMET)

11.5 Provider Service: Integrated Digital Briefing

This is one of the most down-the-stream service facing end users. The service mashes-up all types of operational information in the scenarios, MET, static and dynamic Aeronautical Information and Flight Plan. It is a consumer of the Flight Plan Distribution, Aeronautical Information Feature, Aeronautical Information Feature, METAR/TAF and En-Route Observation services. As such it requires their exposed provided interfaces. In addition is providing ePIB mash-up information over its own exposed provided interface ePIB.

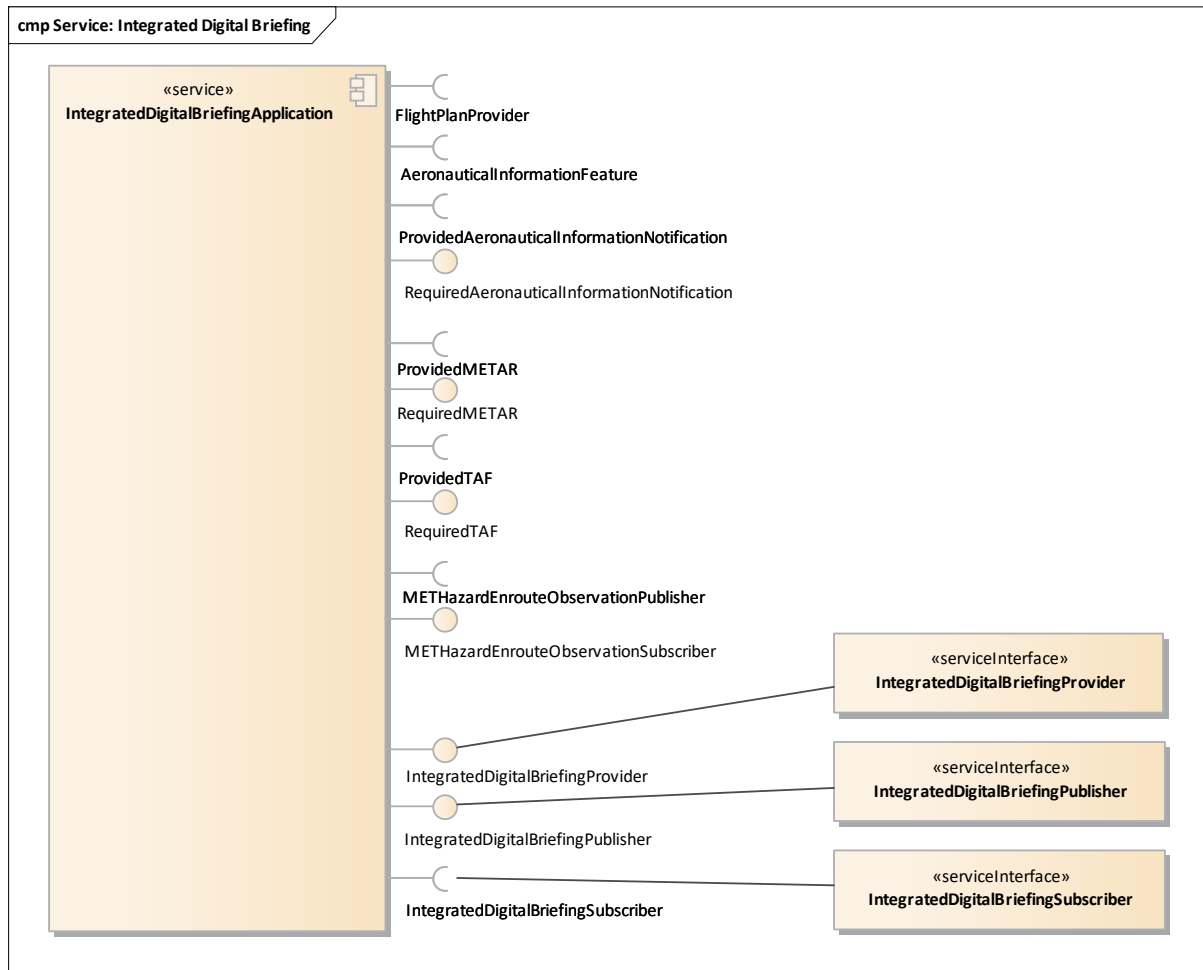





Figure 36: Integrated Digital Briefing Service

The BEST consortium:

<p>SINTEF</p>	
<p>Frequentis AG</p>	
<p>Johannes Kepler Universität (JKU) Linz</p>	
<p>SLOT Consulting</p>	
<p>EUROCONTROL</p>	